

Z Axis

FB210 Series Motorized Linear Axis and Focus Blocks

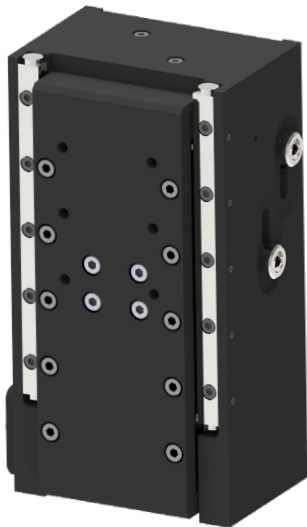

FB210/E



FB212/E

The FB210 single axis stepper motor drive provides a versatile yet highly precise positioning solution for a variety of applications, featuring numerous mounting points for ease of integration. It forms the core of numerous focus block configurations, which have been designed by Prior for use in various microscopy applications to provide accurate and repeatable movement for focusing, sample translation and Z-stacking. The high load capacity of the drive allows Prior Scientific stages of various sizes to be mounted directly, in order to provide a standalone XYZ three axis stage system, fully controlled by Prior's ProScan III controller. The FB212 is a preconfigured solution for upright, reflected light applications. Customized focus block configurations are also easily designed using the FB210 as the base, which is ideal for OEM manufacturing and optical-table-based microscopy systems. Transmitted light and inverted microscopy applications can also be realized in this way. The FB210 and FB212 have the advantage of extended travel range compared to their FB203-series counterparts. In addition, a synchronized dual focus drive version of the FB210 can be used to manage complex loads, as seen in Prior's H189 Motorized XYZ Deck.

Key Features

- Encoded and non-encoded versions
- 50 mm travel range
- Directly compatible with most Prior Scientific XY stages
- High precision ballscrew drive
- Adjustable limit switches

Applications

- Industrial and semiconductor inspection
- Life science imaging
- Customized optical table microscopy systems
- Laser based microscopy
- System integration and OEM manufacturing

Dimensions

FB210/E

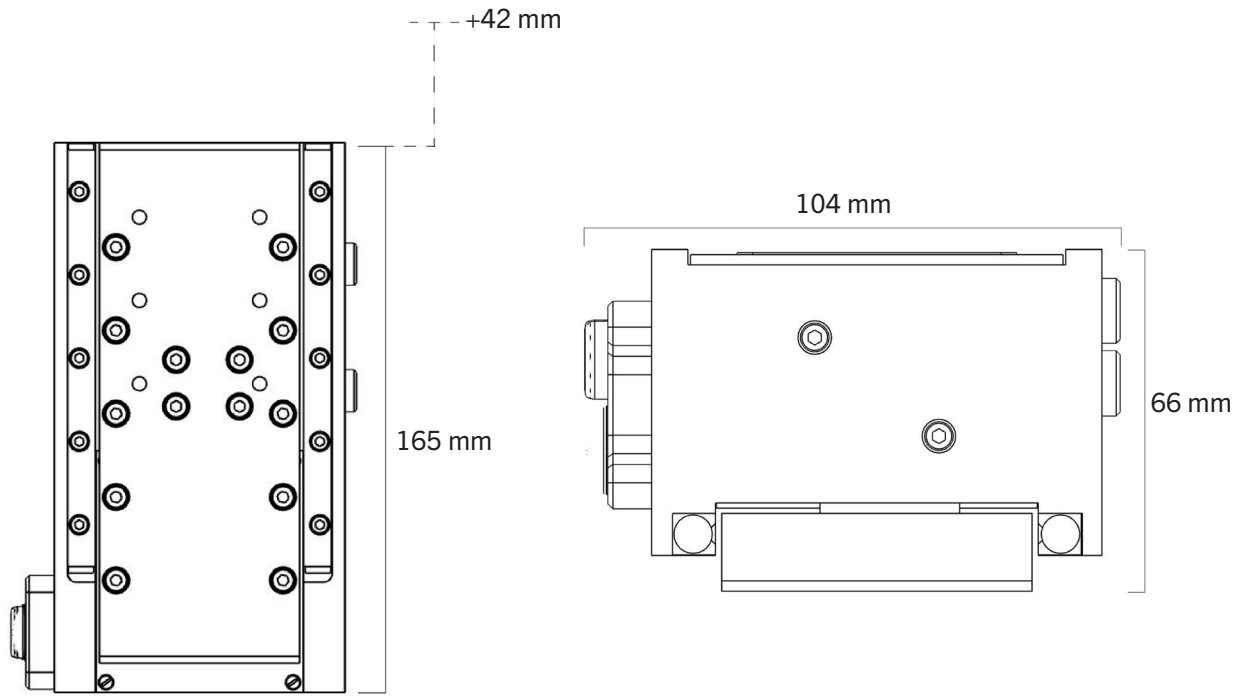

FB212/E

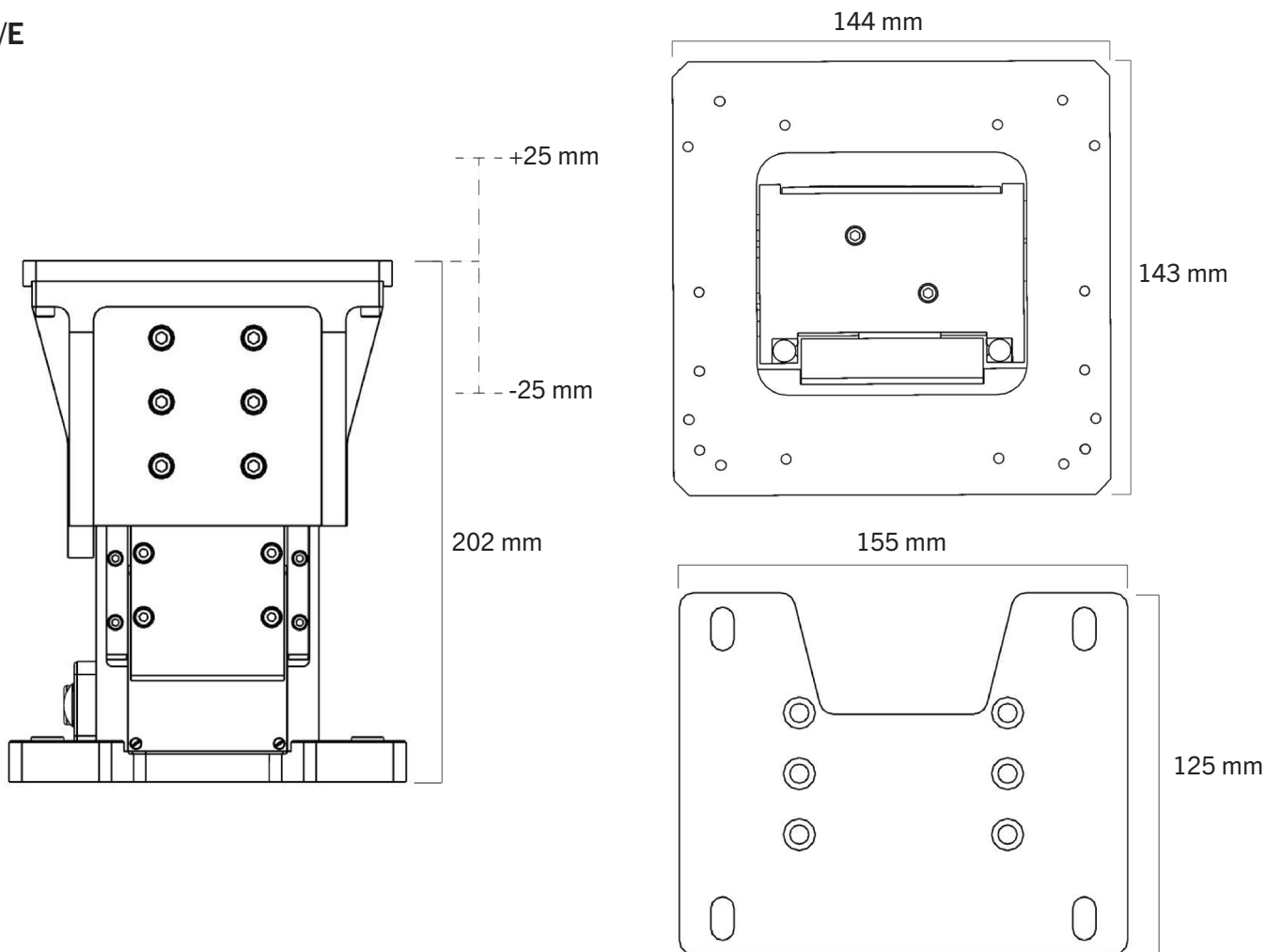

Specifications

	Non-encoded	Encoded
Travel range	50 mm	50 mm
Resolution ¹	20 nm	100 nm
Linearity ²	+/- 4.6 µm	± 4.6 µm
Maximum load	14 kg	14 kg
Repeatability ²	+/- 0.7 µm	+/- 0.3 µm
Accuracy ³	< 6.5 µm	< 6.5 µm
Maximum speed ³	14 mm/s	14 mm/s
Minimum speed ³	1 mm/s	1 mm/s
Cable length	1 m	1 m

¹ Defined as minimum motor step resolution for non-encoded devices, encoder resolution for encoded devices

² Over full travel

³ Under maximum load

All list specifications apply to FB210, FB212 and their corresponding encoded versions when used with a ProScan III controller.

Ordering Information

Part Number	Description
FB210	Single axis stepper motor drive, non-encoded, no brackets, no base, 50 mm travel
FB212	Focus block, non-encoded, brackets for upright reflected light microscopy, standard base, 50 mm travel
FB210E	Single axis stepper motor drive, encoded, no brackets, no base, 50 mm travel
FB212E	Focus block, encoded, brackets for upright reflected light microscopy, standard base, 50 mm travel

Contact Prior Scientific before ordering an encoded system with a ProScan III controller which will also control a HLD117 linear stage.

UNITED KINGDOM

Prior Scientific Instruments Ltd.
Units 3-4 Fielding Industrial Estate
Wilbraham Road, Fulbourn
Cambridge, CB21 5ET
United Kingdom
Email: inquiries@prior.com
Phone: +44 (0)1223 881711

U.S.A.

Prior Scientific, Inc.
80 Reservoir Park Drive
Rockland, MA. 02370
U.S.A.
Email: info@prior.com
Phone: +1 781.878.8442

GERMANY

Prior Scientific Instruments GmbH
Maria-Pawlowna-Str. 4
D-07743, Jena, Germany
Email: jena@prior.com
Phone: +49 (0) 3641 24 20 10

JAPAN

Kayabacho 3rd Nagaoka Bldg 10F,
2-7-10, Nihonbashi Kayabacho, Chuo-Ku,
Tokyo103-0025, Japan
Email: info-japan@prior.com
Phone: 03-5652-8831

CHINA

Prior Scientific Instruments (Suzhou) Ltd.
Room 1812, Honghai Building,
72 Xingdu Street, Suzhou Industrial Park,
Suzhou, 215000 China
Email: info-china@prior.com
Phone: +86 (0)512 6617 5866

