

PLW20

Well Plate Loader
Manual



CONTENTS

SECTION 1 – SAFETY INFORMATION	3
1.1 Important Safety Information	3
1.2 General Guidelines for Use or Operation	4
SECTION 2 – SPECIFICATIONS	6
SECTION 3 – UNPACKING	7
3.1 Unpacking and Inspecting	7
3.2 System Integration	7
3.3 Packing	8
SECTION 4 – IDENTIFYING YOUR SYSTEM	9
4.1 System Diagram	9
4.2 Plate loader movement and axis identification	10
4.3 Connection Identification	10
SECTION 5 – INSTALLATION	11
5.1 Installing your system	11
5.2 Installing the stage onto the microscope	15
SECTION 6 – SETUP OF THE PLW20	18
6.1 Software	18
6.2 Software Screen	18
6.3 Starting setup	18
6.4 Setup of the PLW20	20
SECTION 7 – OPERATION OF THE PLW20	28
7.1 Using the Software	28
7.2 Testing a Setup via Single Step Moves	30
7.3 Testing a Setup via a Soak Test	31
7.4 Typical Screenshots	32
SECTION 8 – ROUTINE MAINTENANCE	34
SECTION 9 – SOFTWARE INTEGRATION	35
SECTION 10 – TROUBLESHOOTING	36
SECTION 11 – RETURNS AND REPAIRS	38

SECTION 12 – APPENDIX

39

- Appendix A – Using Prior Terminal
- Appendix B – Fitting a barcode reader
- Appendix C – Using a barcode reader

Section 1 SAFETY INFORMATION

1.1 IMPORTANT SAFETY INFORMATION

SAFETY WARNINGS

Always observe the following safety precautions

- The PLW20 must only be connected to a power outlet, which provides a protective earth.
- Use only the mains cord supplied. If this does not fit your power outlet, contact your distributor for the correct power lead.
- The unit is heavy and weighs 32kg. Remove the microscope before transporting. It should only be lifted by two people: use side handle and lip of the rear cable entry area to lift safely.
- Always disconnect the equipment before moving.
- This equipment is for use in moderate, indoor conditions only. NEVER use the equipment in damp or wet conditions.
- Avoid excessive heat, humidity, dust & vibration.
- Do not use where the equipment may be subjected to dripping or splashing liquids.
- This equipment contains no user-serviceable parts. Refer all repairs to qualified service personnel.
- Keep fingers and hands clear of the PLW20's moving parts when it is operating.
- It is the user/operators responsibility to ensure good laboratory practise is followed if well plates contain hazardous material.

SAFETY SYMBOLS

Retain these instructions. The following symbols mean:



Warning: read instructions to understand possible hazard



Warning: hazardous voltage

Safety- System Integration

The Prior PLW20 is designed and assessed to have no serious hazards. However it is always used as a component within a complete microscopy system.



1.2 GENERAL GUIDELINES FOR USE/OPERATION.

The PLW20 forms part of an automated microscopy system, which may be used in research or production laboratories. It will pick-up, present, sort and return plates to either of the two preloaded racks that are positioned at the front.

Whilst operating if a plate becomes misaligned, do not attempt to correct this during the operation cycle. Turn off the mains power before correcting plate position or removing any obstruction. Reinitialise the system.

The PLW20 rotary arm may move unexpectedly, under automatic control.

Be aware that when using with a Nikon Ti microscope that you will need to ensure that the objectives and condenser will not clash with the loader system. We highly recommend speaking to a product specialist to ensure no damage occurs to any instrument.



The system should **ONLY** be used with an **EXTRA LONG WORKING DISTANCE** condenser. The **LONG WORKING DISTANCE** condenser is not suitable.

The following objectives are suggested by Nikon to be suitable for use with the PLW20. Be careful when using any objective with a working distance of less than 50 mm.

MRH20041	CFI Plan Fluor DL4X F N.A. 0.13, W.D. 16.4 mm, PhL
MRH20101	CFI Plan Fluor DL10X F N.A. 0.30, W.D. 15.2 mm, Ph1
MRH48230	CFI Super Plan Fluor ELWD ADM 20XC N.A. 0.45, W.D. 8.2-6.9mm, PH-1
MRH48430	CFI Super Plan Fluor ELWD ADM 40XC N.A. 0.60, W.D. 3.6-2.8mm, PH-2
MRF00040	CFI S Fluor 4X N.A. 0.20, W.D. 15.5mm
MRD00025	CFI Plan Apochromat Lambda 2X N.A. 0.10, W.D. 8.5 mm
MRD00045	CFI Plan Apochromat Lambda 4X N.A. 0.20, W.D. 20 mm
MRL00042	CFI Plan Achromat 4X N.A. 0.10, W.D. 30.0 mm

Oil objectives should be used only with extreme caution – consult a specialist before proceeding.

Mercury bulbs **MUST NOT** be used with this system.

If using a camera, it must be mounted on the left hand side of the microscope.

Section 2 SPECIFICATIONS

This equipment is for indoor use and will meet its performance figures within an ambient temperature range 5 to 40°C with maximum relative humidity of 80% humidity (deteriorating linearly to 50% above 31°C).

- Size 570mm deep x 850mm wide x 680m high
- Weight 57Kg gross, (includes Plate loader, all accessories and packaging). 32Kg Net (plate loader fully assembled with accessories, but no packaging). The weight of the microscope is not included in these figures.
- Capacity of 20 slides (2 racks of 10).
- Plate type Standard well plates with and without covers.
- Plate change time of 28 seconds.
- Input Voltage 100v to 240v.
- Fuse rating for both fuses is T2A.
- Communication Via USB.

Section 3 UNPACKING

3.1 UNPACKING AND INSPECTING

Carefully unpack the PLW20 and retain the packaging should the unit need to be returned. If the PLW20 appears damaged in any way, return it to your sales outlet in its original packaging. No responsibility for damage arising from the use of non-approved packaging will be accepted. The packaging includes a pallet, user appropriate pallet lifting equipment to transport the PLW20 in the packaging.

Ensure all items and accessories specified are present.

- PLW20 slide loader and microscope mounting plate
- 10 position well plate hotel (x2)
- Installation/Operating manual
- Microscope Fitting kit
- Cables (mains & USB)

If not, contact your sales outlet or Prior Scientific.

Use only as specified by these operating instructions or the intrinsic protection provided by the unit may be impaired.

3.2 SYSTEM INTEGRATOR

The Prior PLW20 is designed and assessed to have no serious hazards. However it is always used as a component within a complete microscopy system.



The PC terminal must be positioned close to the plate loader so that the PC operator has a clear, unobstructed view of the plate loader. This ensures that the PC operator will be aware of any person or obstructions in the vicinity of the plate loaders moving parts, before starting the loader. A red Fast Stop button can be found on the front of the Plate loader. This can be used to instantly cut the power to the loader, immediately halting any arm movements.

If the plate loader is to be operated remotely, via a web link etc. then adequate procedures should be put in place to either ensure that the operator can view the plate loader, or ensure that no untrained personnel have access.

Read the information in Section 1.2 regarding objective and condenser compatibility.

3.3 PACKING

The PLW20 is securely and safely packed in 3 sections inside the box.

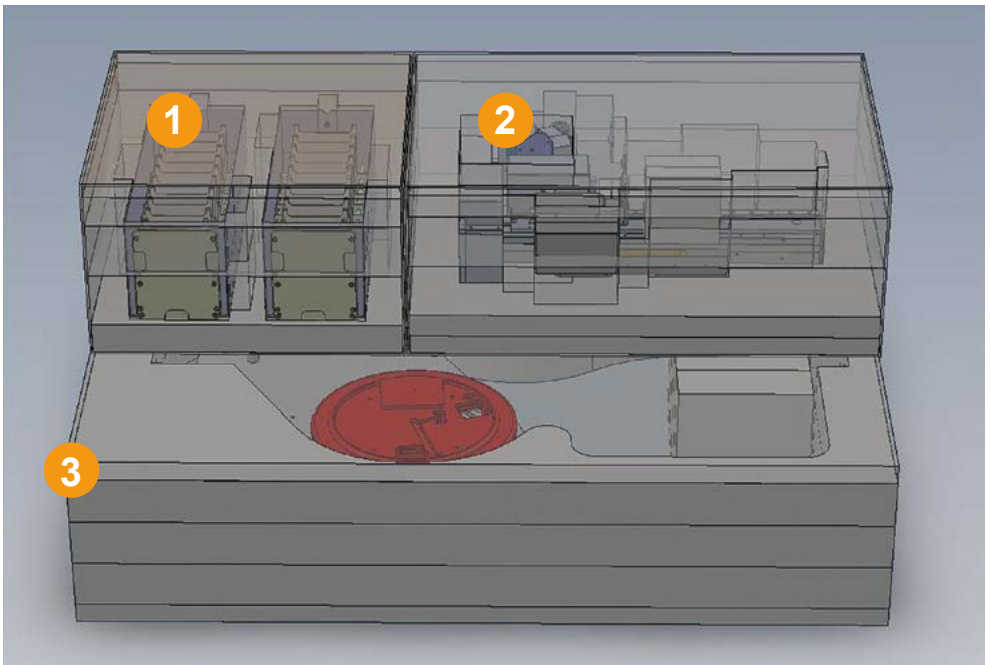

Section one contains 2 x 10 slot hotels.

Section two contains the plate loader tower.

Section three contains the X-axis assembly and base kit.

Section 4 IDENTIFYING YOUR SYSTEM

4.1 SYSTEM DIAGRAM

- 1) Z-Axis arm
- 2) Barcode Reader (optional)
- 3) Gripper
- 4) Y-axis tower
- 5) Base plate
- 6) Hotel Rack 2
- 7) Hotel Rack 1
- 8) Apartment 10
- 9) Apartment 1
- 10) Hotel rack
- 11) Z-Axis linear rail
- 12) Gripper arms
- 13) Barcode reader

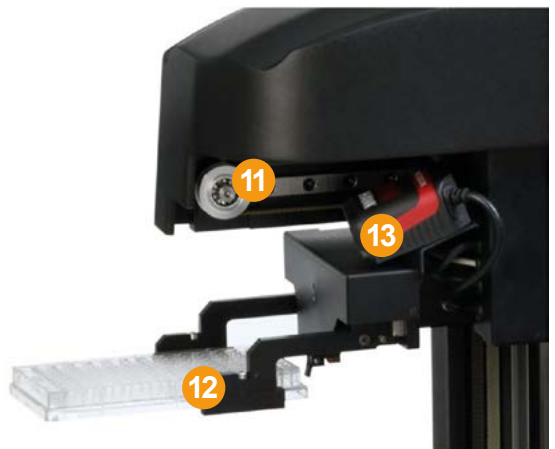
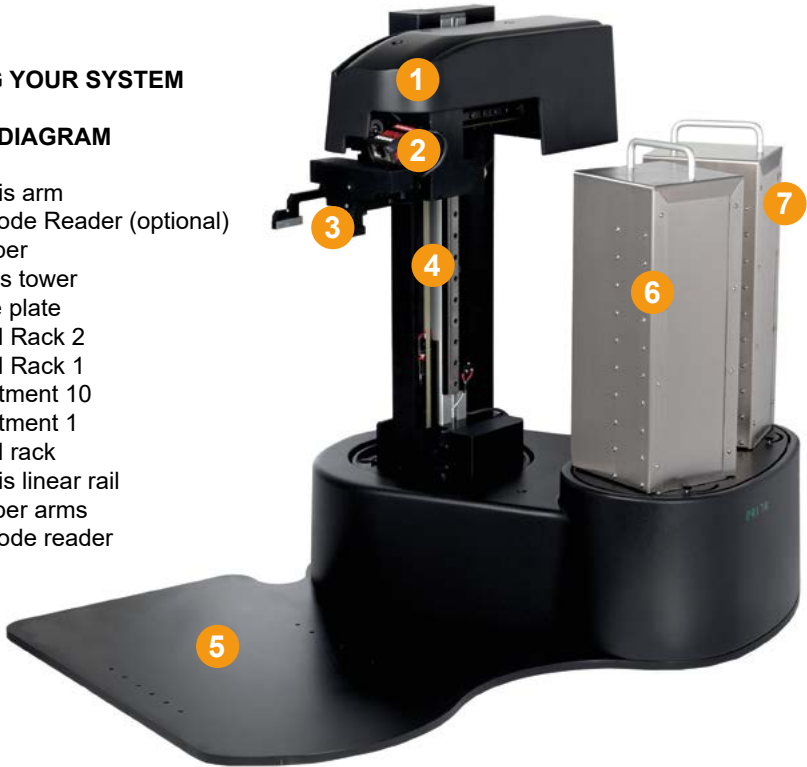

4.2 PLATE LOADER MOVEMENT AND AXIS IDENTIFICATION

Plate loader movement is defined as X, Y, Z, and G. X axis being the rotational movement of the plate loader. Y axis relates to the up and down movement of the loader arm. Z axis Relates to the extend and retract movement of the extension on the gripper arm. Finally, G axis movement relates to the opening and closing of the gripper jaws.

4.3 CONNECTION IDENTIFICATION



- 1) Mains connector
- 2) Fuse housings
- 3) USB connector
- 4) On/off switch
- 5) 4 Way binder socket

Section 5 INSTALLATION

5.1- INSTALLING YOUR SYSTEM

Remove X-axis assembly from packaging case and place on suitable bench. (Fig 1). Note position of the emergency stop (circled).

Remove Y-axis tower assembly from packaging and lower onto x-axis assembly as shown (Fig 2). Ensure mating faces are debris free and aligned correctly. Align D connector on loader arm with the D connector on the loader base. (Fig 3). Once in place ensure that the bottom of the tower is flush with the base before securing with the four M5 screws and the single M3 screw (Fig 02 & 03). With Y-axis tower installed, remove anti rotation shipping screw (Fig 02).

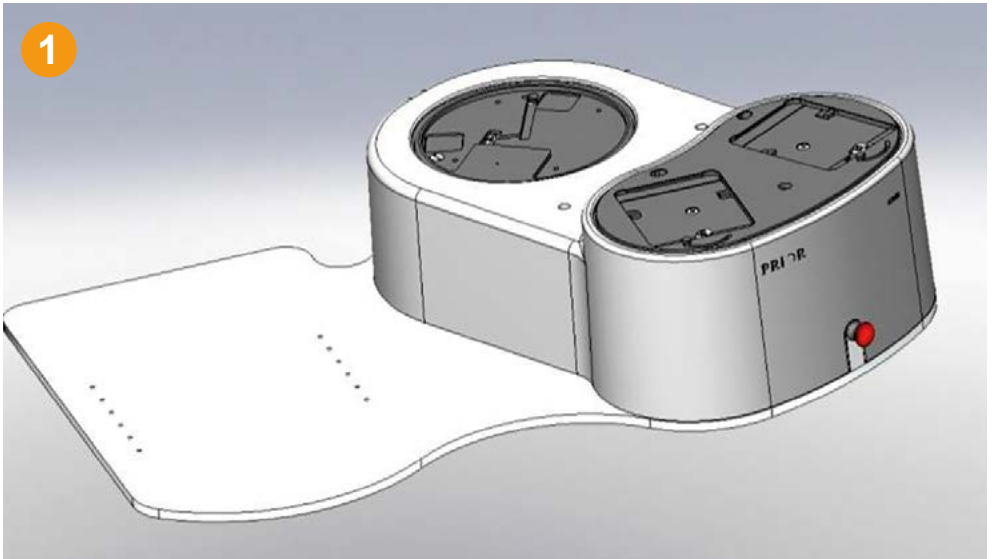

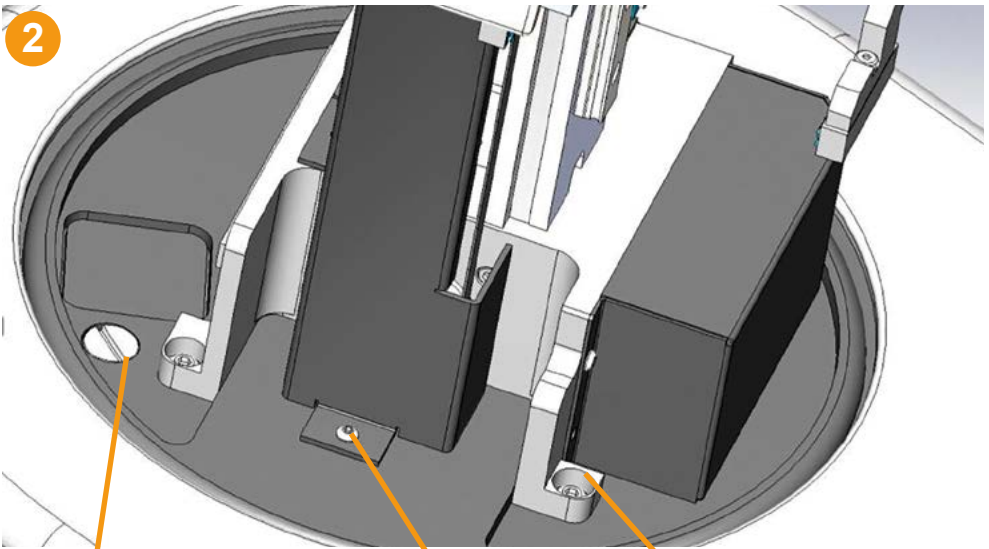

Remove anti rotation shipping screw

INSERT M3 x 6 socket pan head screw to secure

INSERT M5 x 16 socket button head screws into each of four positions and secure firmly.

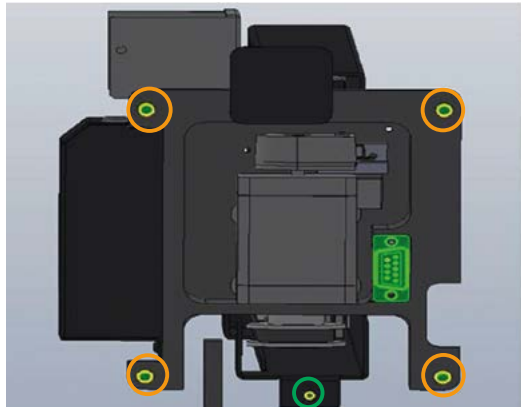
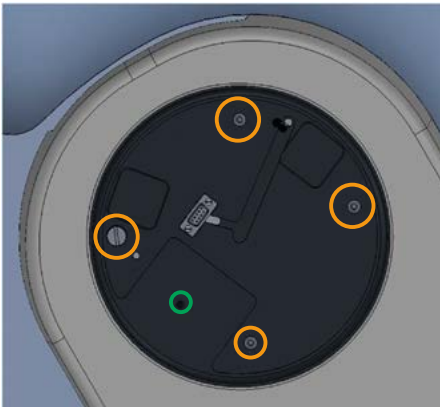

M5 mounting holes are circled in orange, M3 mounting holes in green.

Remove well plate hotels from packaging and fit onto loader plate. Ensure locking clasp is positioned as shown below (Fig 04)

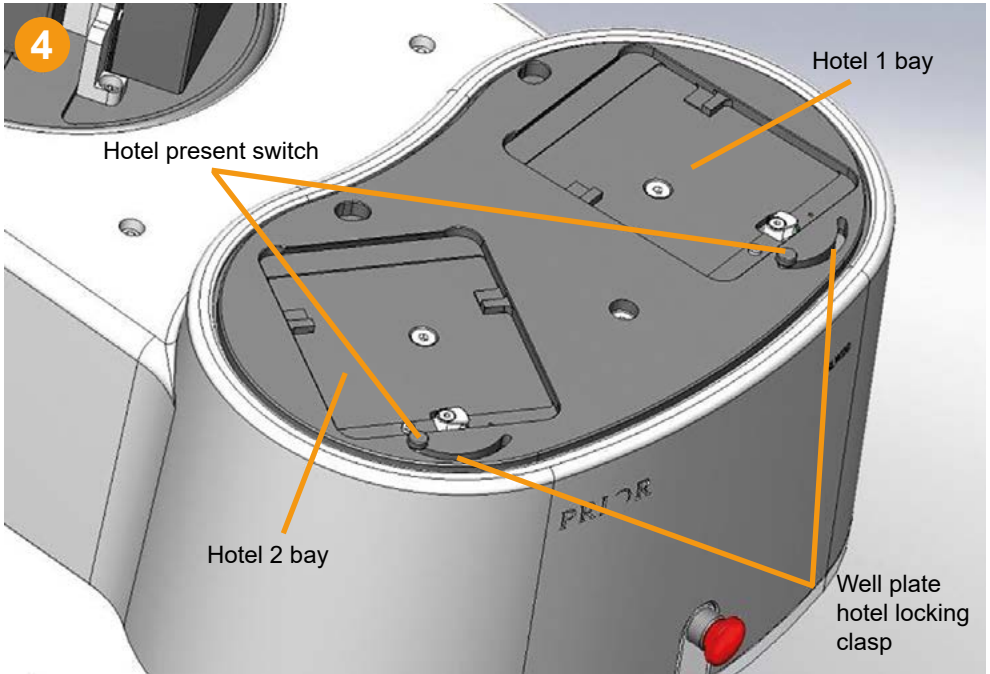

Locate dovetail on front of hotel under the plate dovetail on loader, and lower rear of hotel down onto plate. (Fig 05)

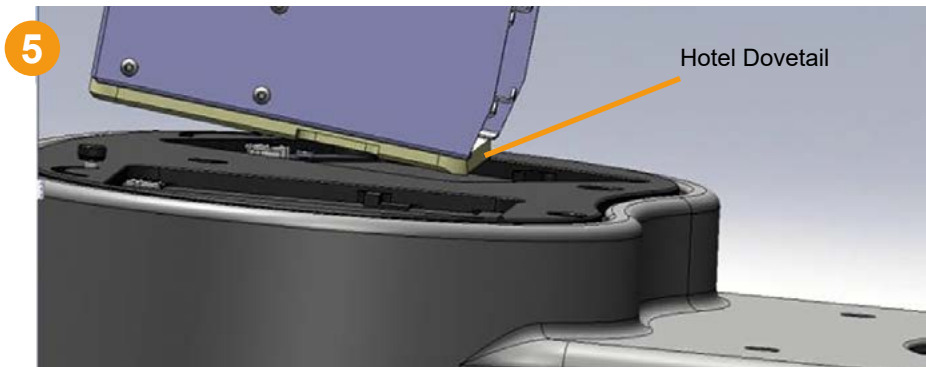

With the hotel in position move clasp to right (Fig 6) to secure the hotel in place and activate 'hotel present' switch. Repeat for hotel 2.

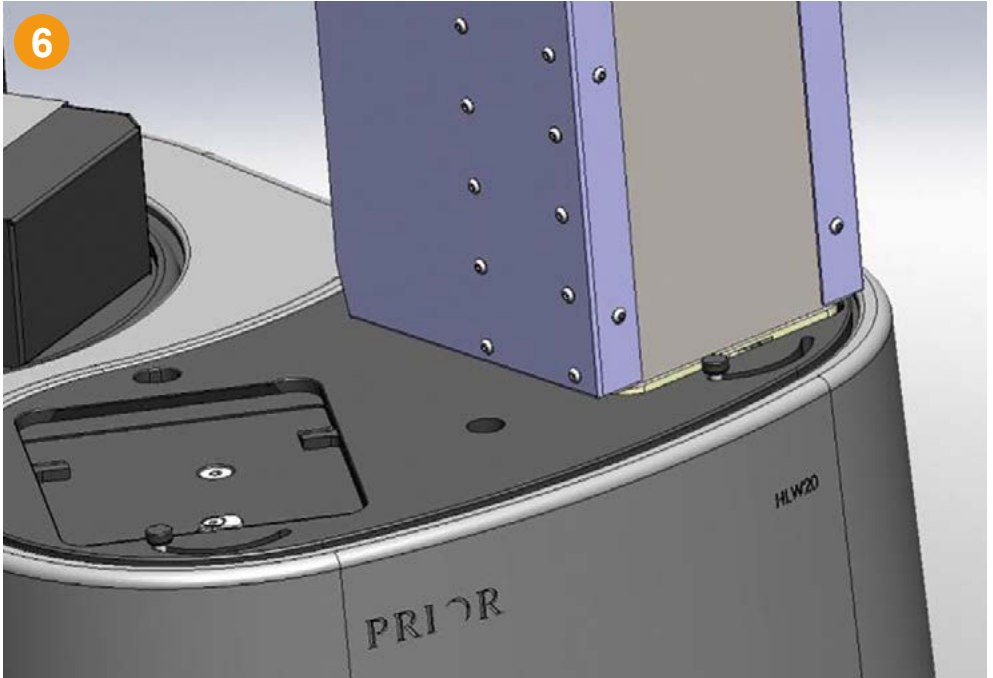

5.2 INSTALLING THE STAGE ONTO THE MICROSCOPE

The Prior ProScan stage is supplied with the correct base plate to suit the microscope specified

1. (Fig 7.1) Fix the H4194 mounting plate onto the front mounting holes on the microscope and fix using the countersunk screws provided (A).

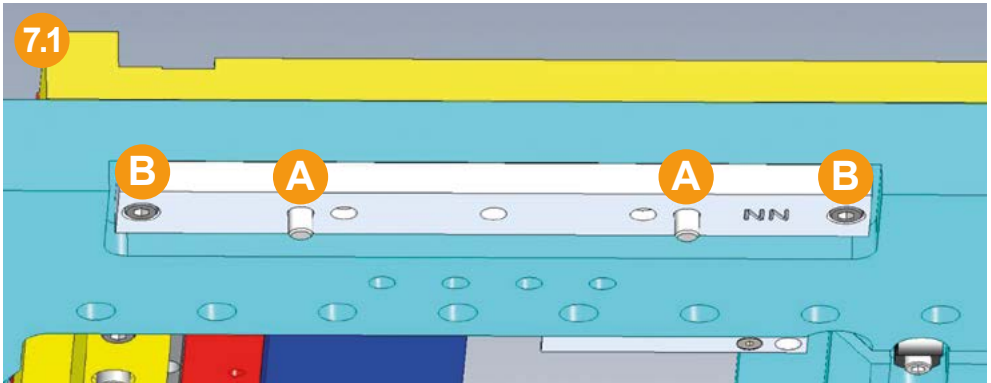

2. (Fig 7.2) Place the stage over the mounting bracket and fix the rear of the stage to the microscope as illustrated. Ensure the cable counting the insert to the PLW20 exits towards the rear of the stage.
3. Viewing the underside of the stage, attach it to the mounting plate, via the fixing points at the extreme ends of the mounting plate (B).
4. Confirm that the ProScan controller unit is switched off before connecting the stage to the controller with the cable provided.
5. The cable connections to the ProScan controller are located on the rear panel of the control box

Before making any of these connections, ensure that the ProScan controller is switched off. Each connection is well labeled but great care should be taken not to try and connect your computer's serial port cable to the 'Z' axis connector on the controller. The RS232 connection from your computer should be made to the RS232-1 port on the controller. For USB connection to your computer see separate section on this subject.

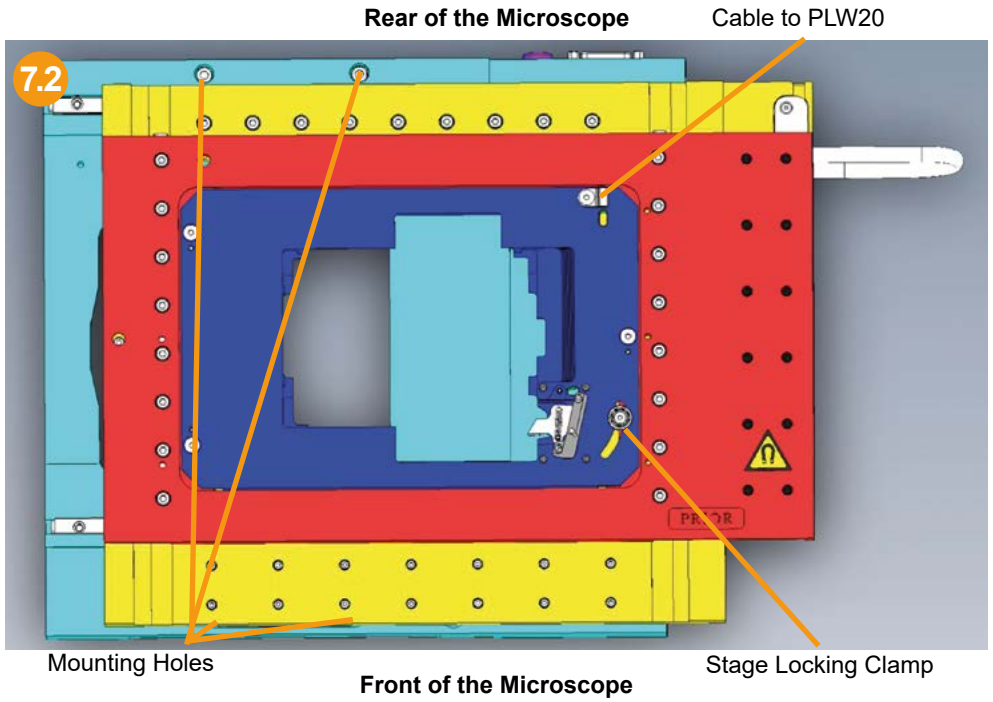

Section 6 SETUP OF THE PLW20

6.1 SOFTWARE

Before working with the PLW20 you must first install Prior software on your PC. Visit Prior software download centre website and download either the 32bit software or 64bit software depending on your Windows operating system. Make sure the software is version v8.4.35 or above.

<http://www.prior-scientific.co.uk/Customer-Support/Download-Centre/>

32bit software download for Window XP and Window 7(v8.4.35): Demonstration programs for ProScan, OptiScan, Slide Loader and Plate Loader; USB drivers and PCI card drivers.
Or

64bit software download for Window XP and Window 7(v8.4.35): Demonstration programs for ProScan, OptiScan, Slide Loader and Plate Loader; USB drivers and PCI card drivers.

After installation of the software, you can locate the “WellPlateLoader demo” program under the Prior Scientific/Visual Basic folder of the Windows start menu.

If you are using Windows 7 plug in the USB cable to the PLW20 and the computer, and power on the PLW20. The device should be automatically recognised and the appropriate drivers installed. For other operating systems please contact Prior Scientific or your local dealer.

6.2 SOFTWARE SCREEN



6.3 STARTING SETUP

Note: A red Fast Stop button can be found on the front of the Plate loader. This can be used to instantly cut the power to the loader, immediately halting any arm movements. This button must be release before power can be returned to the loader.

It is important for the plate loader to initialize to known datum points before you can proceed with the setup procedure. The datum points are the limit switches which define the end points of the travel for the X, Y, and Z of the loader.

Before beginning the initialisation procedure remove any hotels (well plate cassettes) from the loader and make sure that nothing is in a position where the loader can collide with it.

1. Switch on the Well Plate Loader.
2. Open Prior Well Plate Loader software. (Fig 10)
3. Click “Connect”, on the menu bar.

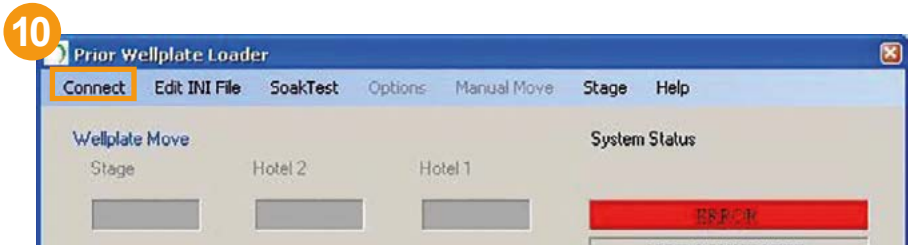

4. Enter or confirm the “Well Plate Loader Comm port” number and the “Prior Stage Controller Comm port”. (Fig 11) The port address is automatically assigned by Windows but can be confirmed through the systems Device Manager.

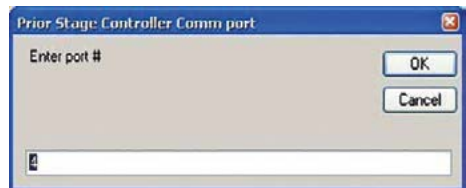
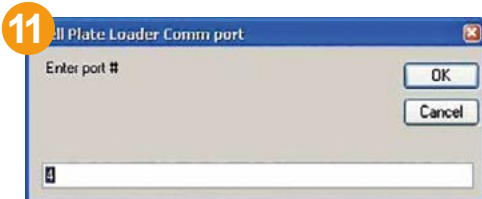

5. The manual mover screen will appear (Fig 12), use this to move the loader to a position clear of the stage and about half way up the Y axis.

If a warning appears indicating that a well plate is in the gripper, manually remove this well plate and continue. Use the G button in the manual mover screen to open the gripper, remember to place a hand under the well plate to catch it as the gripper arms open.

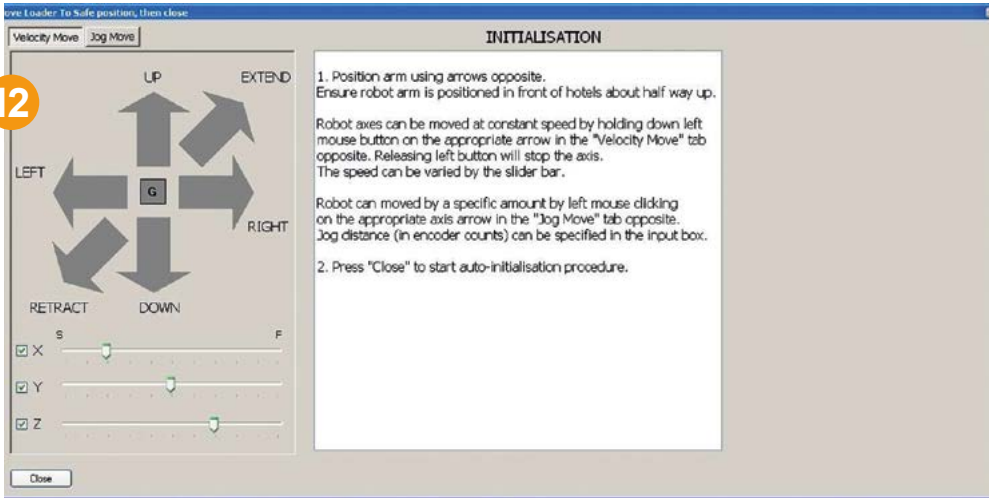

Closing the manual move screen will bring up the following window (Fig 13).



Click 'OK' to continue. The stage will then move to its Load Position and the loader will automatically perform initialisation. Once this is completed the setup procedure can begin.

6.4 – SETUP OF THE PLW20

After the initialisation step has been completed, you are required to complete a set up procedure. If a set up has not already been completed then the manual mover screen will reappear. It can be controlled via either velocity move or jog move.

For Velocity Move, the manual move window (Figure 14) will allow you to move the loader along the X,Y and Z axis using the appropriate arrow keys. The buttons relate to the following movements.

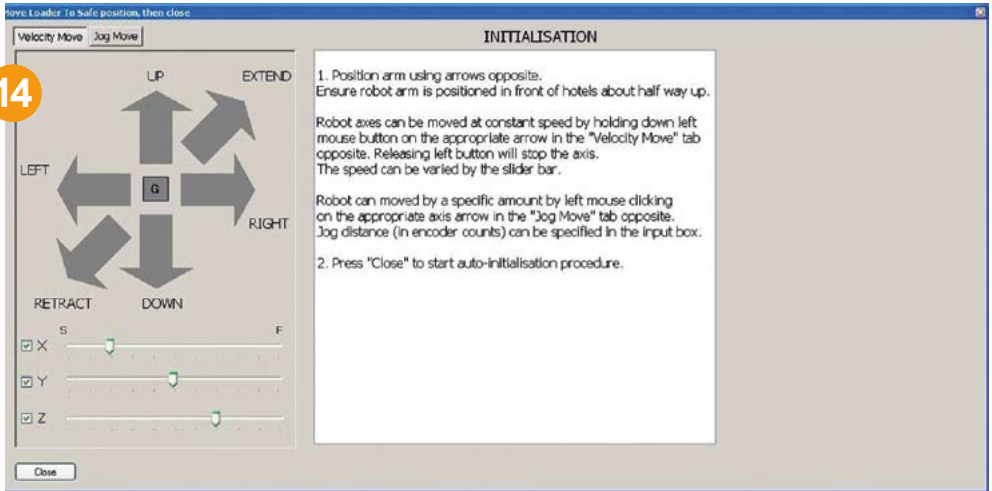

X – Tower rotation axis – rotate the tower by using the LEFT and RIGHT buttons.

Y – Arm height – move the arm up and down using UP and DOWN buttons.

Z – Arm position – retract and extract using RETRACT and EXTRACT buttons.

G – Gripper cycles open/close when pushing the G button.

The speed of movement along the axis can be controlled using the axis slider bar (Fig 15). Moving the slider to the left slows movement, moving it to the right increases speed. Tick the boxes to enable or disable the axis.

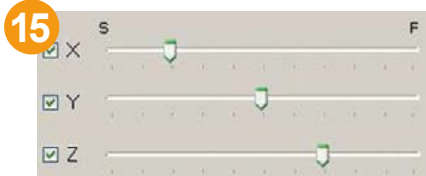

When making final adjustments, use the slowest speed for accurate control. Or use the Jog move.

The jog move moves the loader a predetermined distance per click. See above for which arrows correspond to which direction.

The speed of movement along each axis can be controlled by changing the value of the encoder count (Fig 16). The larger the number the further the arm will move per click. Tick the boxes to enable or disable the axis.

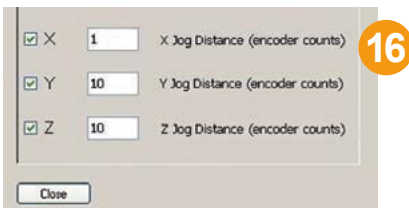

A red FAST STOP button can be found on the front of the well plate loader. This can be used to instantly cut the power to the loader, immediately halting any arm movements. This button **MUST** be released before power can be returned to the loader.

Move the gripper to the Hotel1 reference point.

Check that the gripper arms are central in the insert, flush with the base and the leading edges of the gripper paddles are flush with the set up tabs and the base of the paddles are just resting on the base tabs. See Fig 17.

17

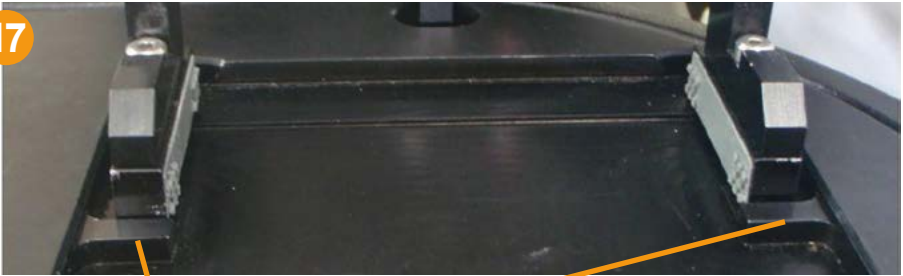

Set up tabs

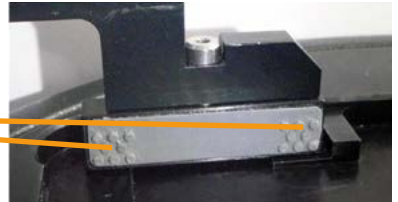
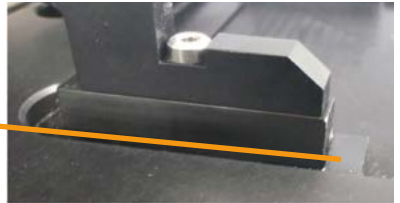

Base tabs

Click 'Next' to save the hotel setup position. When the software asks for confirmation of the Hotel Setup Position, click 'Yes'.

Click 'Next'. The loader will now move the gripper arm to a safe position, ready for the next stage of the setup (Figure 18).

18



Click 'Next'.
The 'Fit Hotel' window will now appear.

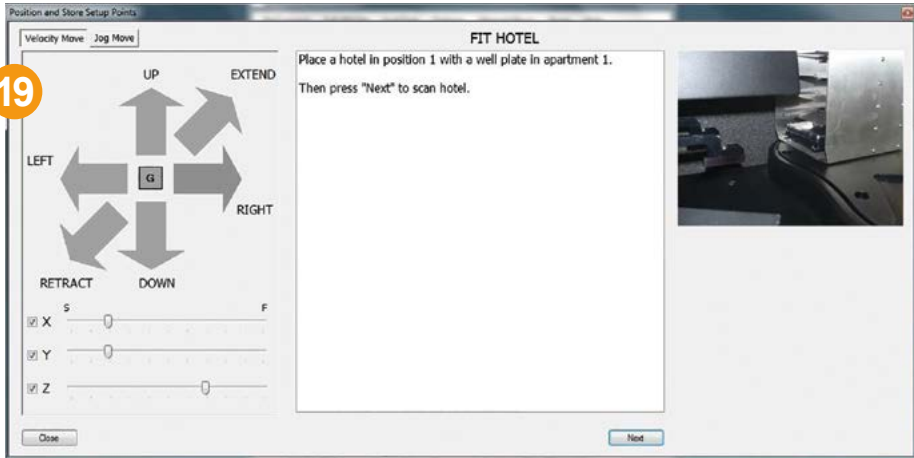

Place a Hotel onto its pay in position 1 of the well plate loader's main body. Insert a well plate into apartment 1 of the Hotel. Click the 'Next' button.

The 'Scanning Hotel' window will appear and the loader will automatically scan Hotel 1, pick up the well plate and move it to a safe position above the stage (Figure 20).



Click 'Next' to continue to the 'Wait Until Robot Stops Moving' window (Fig 21).

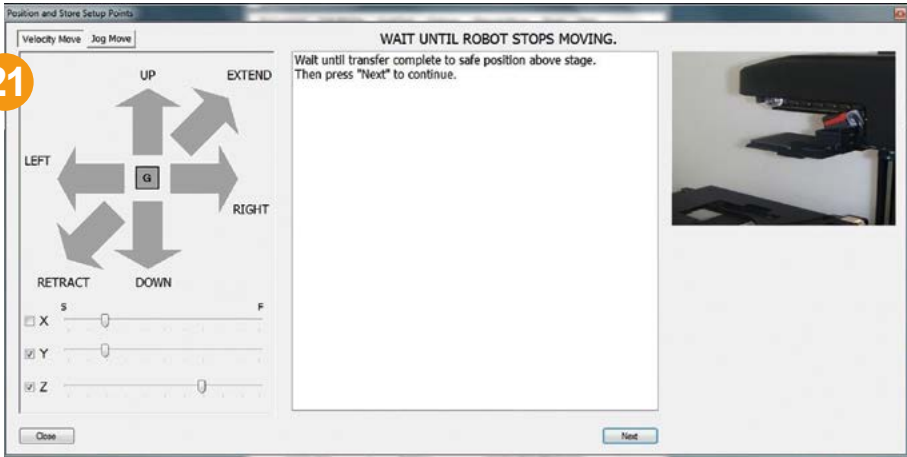

Once the loader has finished moving the gripper arm, click 'Next' to continue. The 'Store Stage Setup Point' window will appear (Fig 22).

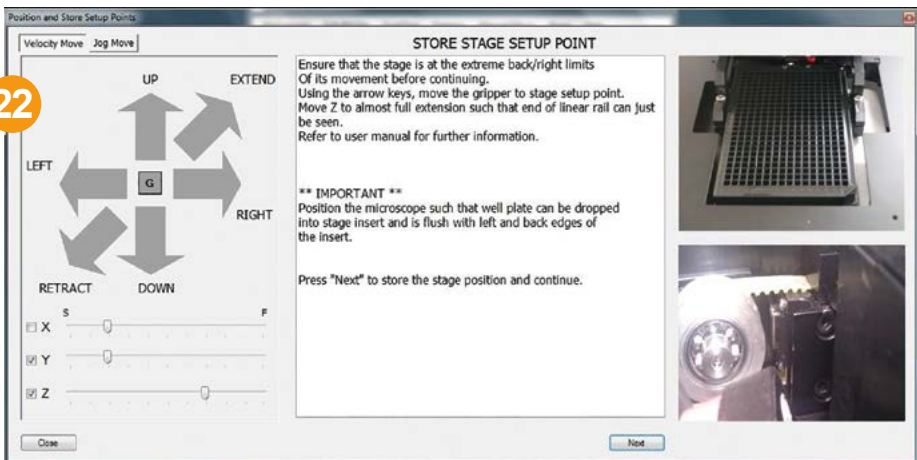

**THE STAGE MUST BE AT ITS LOADING POSITION
(AS FAR BACK AND FAR RIGHT AS CAN BE).**

Use the manual mover arrows to firstly extend the gripper arm to almost its maximum limits along the Z axis. You should be able to just see the end of the Z axis linear rail. Move the gripper arm down the Y axis until it has come to a rest just above the motorised microscope stage. Make sure that the stage clamp is in the OPEN position, as shown in Fig 23.



Position the microscope such that the well plate can be dropped into the stage insert without the gripper arm clashing with the stage. Use the manual mover arrows to carefully position the well plate inside the stage insert.

Fine adjustment of the microscope's position maybe required now. Position the microscope such that the well plate rests against the tabs on the back and left of the stage insert.

A setup tool is provided to aid this procedure see Fig 24, 25 and 26. Use the manual mover keys to slowly adjust the height of the Y axis to carefully lower the well plate inside of the stage insert. The well plate should be positioned such that it just rests on the insert face of the stage; flush with the setup tool.

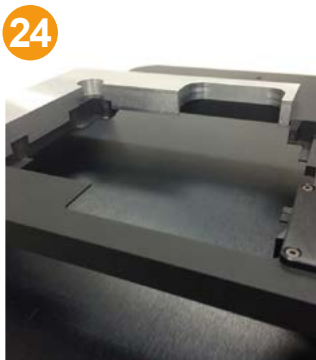

When you are satisfied with the positioning, click 'Next'. Click 'Yes' to confirm the position. Click 'Next' to continue (fig 27).

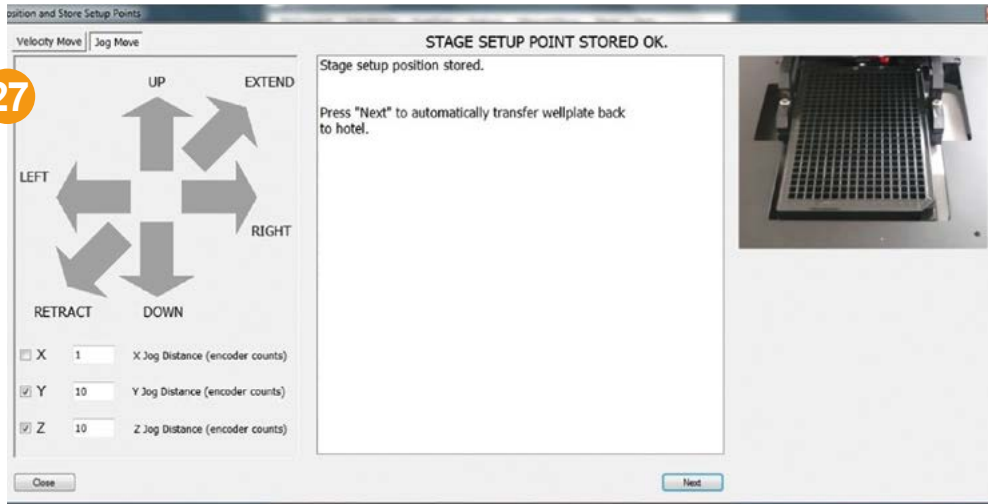

The loader will now pick up the well plate from the stage and position it back into Apartment 1 of Hotel 1 and the following window will appear (fig 28).

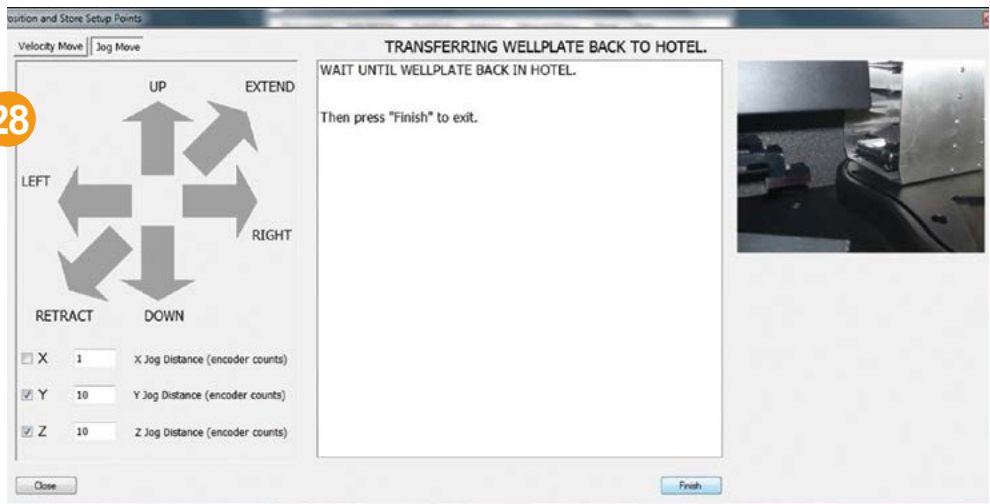

Click 'Finish' to complete the setup.

The microscope should now be in the optimal position for loading. Thus it should be fixed in this position.

Fix the microscope locking blocks in position and gently rest the pads against the microscope to fix it in position (circled, Fig 29 and 30).



Section 7

OPERATION OF THE PLW20

7.1 – USING THE SOFTWARE

The Prior demo software can be used to run and test the installation and set up of the Well Plate Loader. The functions of the application can be located in the menu bar (Fig 31).

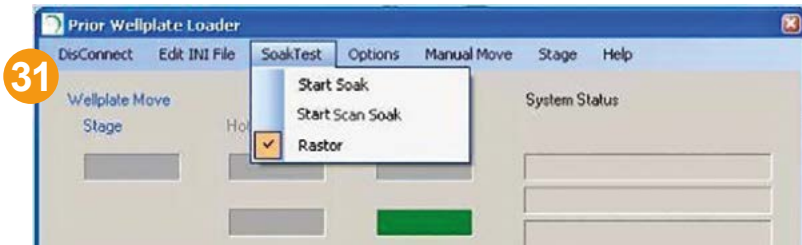

Connect / DisConnect

This will establish a connection from the PC to the WellPlate Loader. When the Loader is connected to the PC the button changes to 'DisConnect'.

Edit Ini File

Starts up notepad.exe so that the setup configuration parameters can be manually edited. This should only be edited by a competent and knowledgeable person after contacting Prior Scientific.

Soak Test → Start Soak

Initiates an automatic process that cycles through all detected well plates moving them first to the stage and the reloads them to their original point. The soak test will continue to load/unload well plates until the "Stop Soak" is pressed, at which point the system will stop when it has finished the current operation. (ie the load to stage step or the unload from stage step).

Soak Test → Start Scan Soak

Initiates an automatic process that first Scans the hotels before it cycles through all detected well plates moving them first to the stage and the reloads them to their original point. The Scan Soak test will continue to load/unload well plates until the “Stop Scan Soak” is pressed, at which point the system will stop when it has finished the current operation. (i.e. the load to stage step or the unload from stage step).

Soak Test → Rastor

If this is checked then the stage will carry out a small rastor movement once the well plate been loaded onto the stage during the soak procedure.

Options → RedoSetup

Initiates the set up procedure, should you need to redo the set up.

Options → Initialise

Forces loader to perform its auto initialisation sequence. NOTE if the loader is in a compromised position the automatic re-initialisation may result in a collision. The user should ensure that the loader is clear to move before continuing.

Options → Single Step Enable

If checked then the loader will enter single step mode whereby the user can step the loader through its cycle. The Single Step button will appear on the main software interface. This option is useful during installation to verify operation in a controlled manner.

Manual Move

Initiates the manual move window. This can be used to manual move the position of the loader arm.

Stage → Move Stage to Load

Moves the stage to the load position ready to receive the well plate.

Stage → Move Stage to Scan

Moves the stage to the scan position ready to scan the well plate.

Help

Contains useful information relating to the Prior Demo software.

7.2 – TESTING SETUP VIA SINGLE STEP MOVES

1. Add plates to the hotels and mount hotels onto the well plate loader base.
2. Press 'Scan' and the loader will automatically scan the hotel and record the location of any well plates present. If a well plate is located in an apartment it will be indicated as a green bar (Fig 32)

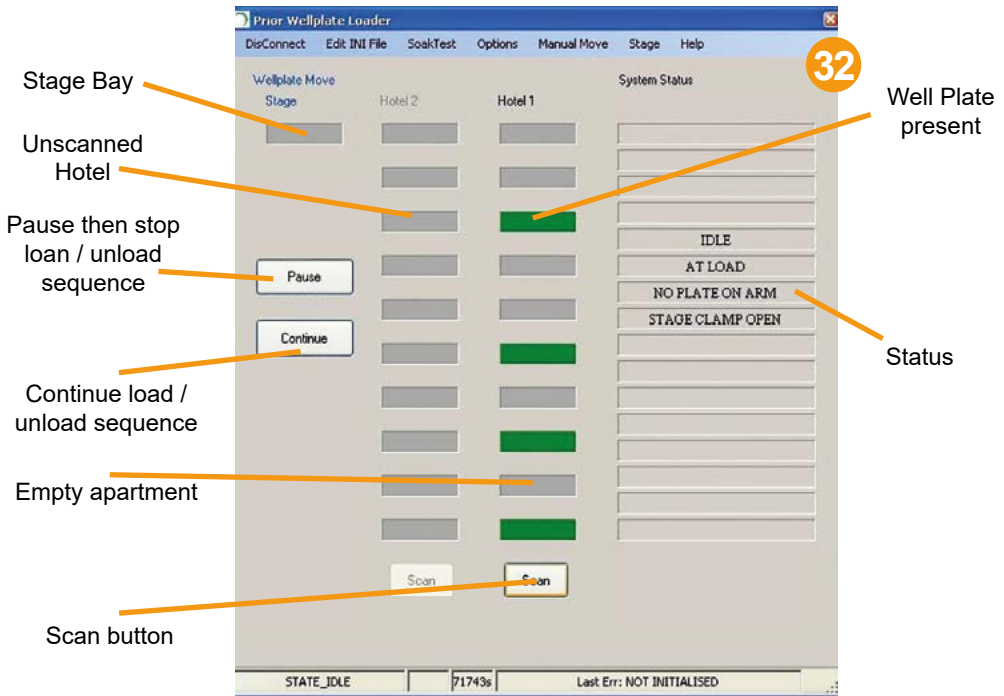

3. Go to Options and check Single Step Enable (Fig 41). The 'Do Single Step' button will now appear.

4. To transfer a well plate from the hotel to the stage position left click on the appropriate well plate in either 'Hotel 1' or 'Hotel 2', then left click on the 'Stage' box and the loader will begin to load the well plate onto the stage.

5. Using the 'Do Single Step' button click through the sequence of steps until the plate is loaded onto the stage. The Status will read 'Active' will the loading procedure is in process.

6. The single steps allows you to check the position of the plate at every stage of the load/unload sequence. If the plate does not load correctly go to Options →Redo Setup and go through the set up procedure again.
7. The sequence of events will end when the status reads back 'Idle'.

7.3 TESTING A SETUP VIA SOAK TEST

1. Add plates to the hotels and mount hotels onto the well plate loader base.
2. Press 'Scan' and the loader will automatically scan the hotel and record the location of any well plates present. If a well plate is located it will be indicated as a green bar.
3. Go to Options Soak Test →Start Soak. The loader will begin to load and unload the well plates in sequence until the Soak Test →Stop Soak command is clicked.
4. The Soak test can be paused or continued using the buttons on the screen.
5. If the Soak Test →Rastor is selected then during the Soak test the stage will also perform a rastor move.



Beginning of a load sequence, when the loader is 'Active'.

Plate selected and status now shows 'Active' indicating the load process has started.

Status reading 'Plate on Arm', indicating that the gripper has picked up the well plate.

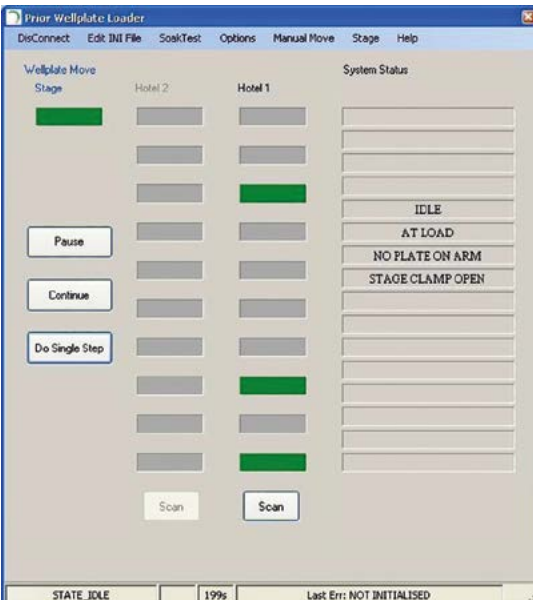

Well plate loaded onto stage, loader idle.

Plate loaded to the stage position, indicated by green bar in 'Stage' bay. Status reads 'Idle' indicating that the move is complete.

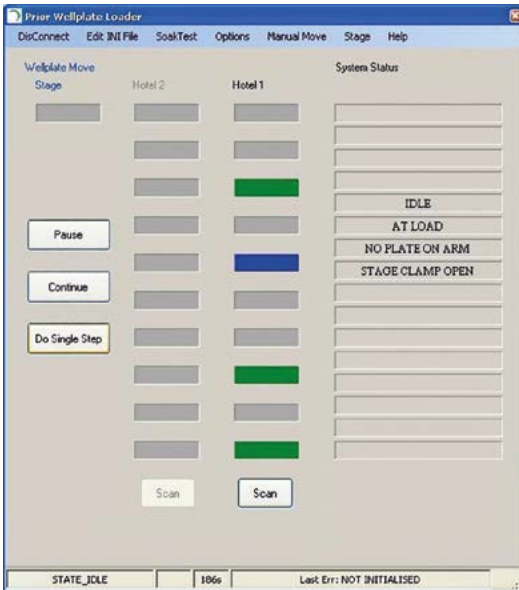

Well plate scanned and returned to hotel, Loader 'idle'.

Blue bar indicates a plate that has been successfully loaded onto the stage and returned back to the hotel.

Status reading 'Idle' indicates that the move is now complete.

Section 8
ROUTINE MAINTENANCE



SAFETY – MAINTENANCE

- Clean with a clean, slightly dampened cloth. Do not wet or allow moisture to penetrate the unit. Do not use solvents on the plate loader as these may stain or damage the plastic covers.
- To ensure correct plate handling it is important that the interface between the plate hotels and the plate hotel mounting face is kept clean and free of debris.
- Remove dust and debris from the plate hotel mounting plate using a brush.
- If the plate hotels should become soiled they can be cleaned using your laboratories standard cleaning procedure.
- The PLW20 only contains primary circuits with EMC filters. If PAT testing, apply DC flash tests only. Avoid repeated application of such tests as this may damage insulation.
- This equipment contains no user-serviceable parts. Refer all repairs to qualified service personnel.
- Opening the product voids the warranty.
- Oil and residue removal - Rinse the plate hotels in your laboratories designated cleaning solvent to remove the oil. (Refer to your health and safety procedures on using this solvent).

IF IN DOUBT PLEASE CONTACT PRIOR SCIENTIFIC

Section 9 SOFTWARE INTEGRATION

The information required for software integration is included in the software development kit. This can be downloaded from the Prior Scientific website. Please go to the Prior software download centre and download either the 32bit software or 64bit software depending on your Windows operating system; Make sure the version number is v8.4.35 or above (Fig 47).

32bit software download for Window XP and Window 7(v8.4.35): Demonstration programs for ProScan, OptiScan, Slide Loader and Plate Loader; USB drivers and PCI card drivers.
Or

64bit software download for Window XP and Window 7(v8.4.35): Demonstration programs for ProScan, OptiScan, Slide Loader and Plate Loader; USB drivers and PCI card drivers.

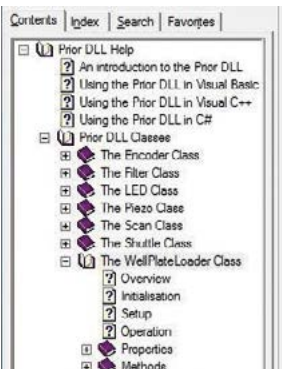
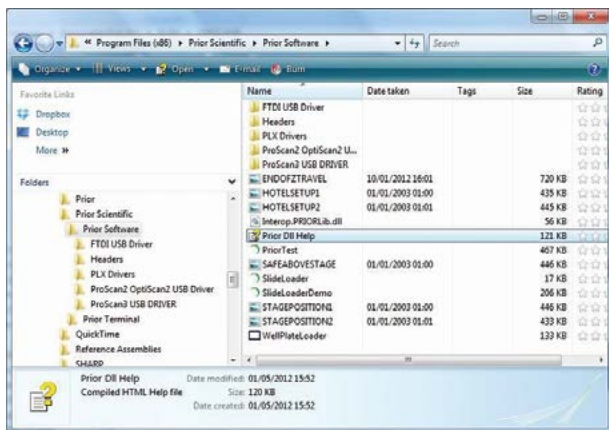

Section 10 TROUBLESHOOTING

Note that some error messages may necessitate reinitialising the loader.

NOT INITIALISED

Plate Loader has not initialised

Goto Options → Initialise to begin initialisation process

NOT SETUP

Plate Loader has not been set up

Goto → Redo Setup to begin set up procedure

STAGE NOT AT LOAD POSITION

The motorised stage is not at the load position ready to accept the well plate.

Move the stage to the load position using either the joystick or Stage → Move to Load function.

WELLPLATE CLAMP CLOSE

Stage clamp is closed preventing the well plate from successfully being loaded.

Move the Stage Clamp to the open position. (See Fig 35)

HOTEL IN USE REMOVED

The software believes the Hotel is not present. This could be due to

i) The hotel being physically removed during the process of transferring the plate to or from the hotel.

Or

ii) Failure of the hotel location sensor

Check to see if hotel is present.

Check to see if the sensor status changes as you move the hotel location sensor from open to close. If there is no change in the sensor status, the sensor has failed please contact Prior Scientific.

STAGE MOVED OF LOAD POINT

The stage has moved from its loading position during transfer of the well plate.

Make sure the stage is returned to the load position either with the joystick or Stage → Move to Load function.

COMMS ERROR – Disconnect/Connect

Results from failure to establish communication with the loader. This could be due to either; No Power to robot; USB connection failed.

Check power connections. Check Device Manager to make sure USB driver loaded correctly. Consult Prior Scientific if using an operating system other than Windows 7+.

AXIS STALLED

The loader arm has stalled on either X,Y or Z axis. This could have been caused by either; i) A physical obstruction preventing movement.

Or

ii) It could also occur if some discontinuity exists between the true position of the loader and where the software actually thinks it is.

Remove the physical obstruction if any present. If none is present, this indicates problems with the encoder or motor. Please contact Prior Scientific.

GRIPPER HOMING FAILED

Gripper fails to home during initialisation

Problem with the sensor, please contact Prior Scientific.

WRONG GRIPPER SENSOR READING

The sensor incorrectly detects if a well plate is present or not. Possible causes could be; Plate removed from hotel after a scan → replace the plate in rack and restart scan.

Or

Gripper malfunction. – contact Prior Scientific.

Section 11 RETURNS AND REPAIRS

The PLW20 contains no user serviceable parts. Attempting to repair or disassemble the unit will void the warranty and likely damage the unit. If the unit is not working, first contact either your distributor or Prior Scientific directly. If you wish, or are advised to, return your unit, a RMA number must first be obtained by filling in a returns form located on the prior.com website. We will then send you an RMA number which should be added to a decontamination form again located on the Prior Scientific website. Do not attempt to return this unit before such a number is obtained.

Prior Scientific office locations:

Prior Scientific Instruments Ltd.

3-4 Fielding Industrial Estate
Wilbraham Road, Fulbourn
Cambridge
CB21 5ET
United Kingdom

Email: inquiries@prior.com
Phone: +44 (0)1223 881711
Fax: +44 (0)1223 881710

Prior Scientific Instruments GmbH

Hans-Knöll-Str. 6
D-07745 Jena
Germany

Email: jena@prior.com

Phone: +49 (0)3641 675 650
Fax: +49 (0)3641 675 651

Prior Scientific Instruments (Suzhou) Ltd.

509 Tayun Plaza, 188 Tayun Road
Suzhou, 215000
China

Email: info-china@prior.com
Phone: +86 (0)512 6617 5866

Prior Scientific, Inc.

80 Reservoir Park Drive
Rockland, MA. 02370
U.S.A.

Email: info@prior.com
Phone: 781.878.8442
Fax: 781.878.8736

Prior Scientific KK

Kayabacho 3rd Nagaoka Bldg 10F,
2-7-10, Nihonbashi Kayabacho
Chuo-Ku
Tokyo103-0025
Japan

info-japan@prior.com
Phone: 03-5652-8831

Section 12 APPENDIX

Appendix A: Using Prior Terminal

Click on the Windows Start menu and go to 'All Programs'. Go to 'Prior Scientific' and select 'Visual Basic'. From this, go to 'Prior Terminal' and open that program. Other programs are also available. The 'Controller Demo' will be covered later in this guide. Since the other programs are specific to a particular product, instructions for these are covered in the respective manuals.

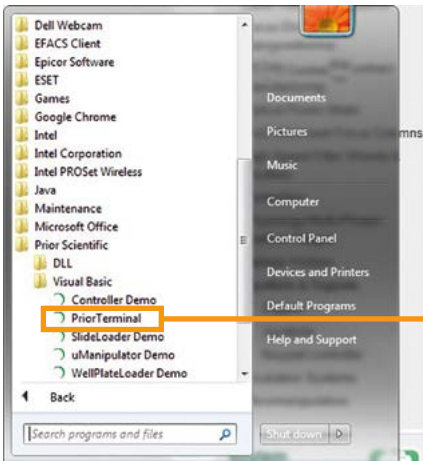

Prior Terminal – click on this to select

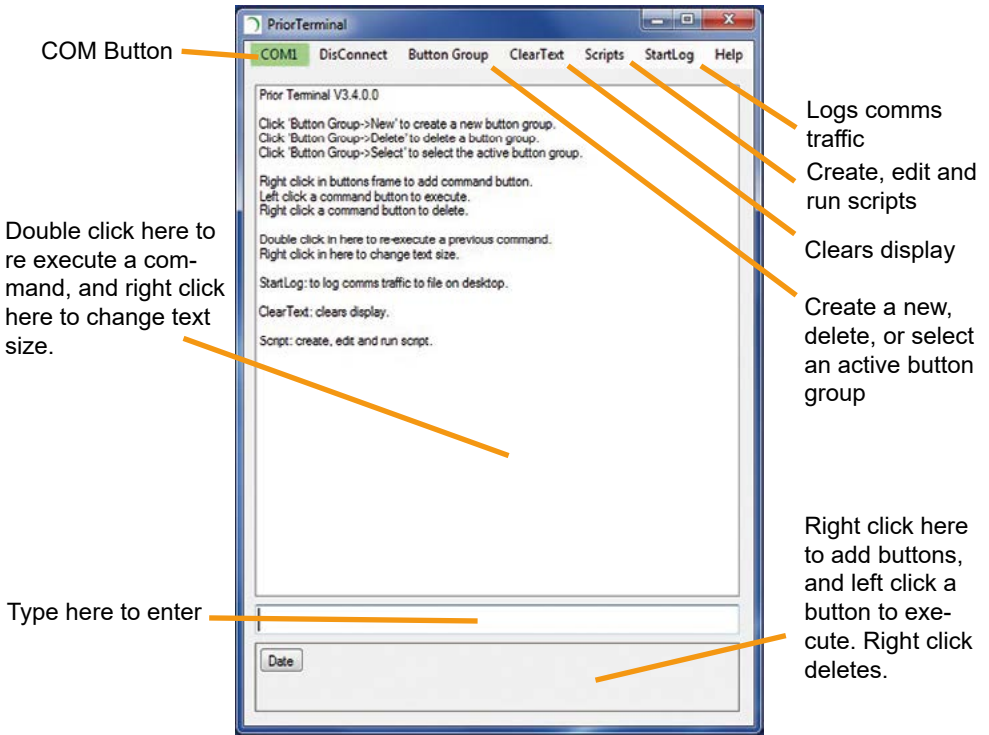

It is important to select the correct COM Port to allow the system to function. This is done by clicking 'Com', which also allows the baud rate to be changed. The default setting of the controllers is 9600; however some software can change this. Once Prior Terminal is open, to list what hardware is connected type '?'. From the product manual you should see the correct response this should generate. For example, from the ProScan III one might get the response:

```
PROSCAN INFORMATION
DSP_1 IS 3-AXIS STEPPER VERSION 0.0
DSP_2 IS 3-AXIS STEPPER VERSION 0.0
DRIVE CHIPS 111111
JOYSTICK NOT FITTED
STAGE = H101AENC
FOCUS = FB20X
FOURTH = NONE
FILTER_1 = NONE
```

```
FILTER_2 = NONE  
SHUTTERS = 001  
LED = 0000  
TRIGGER = NONE  
INTERPOLATOR = NONE  
AUTOFOCUS = NONE  
VIDEO = NONE  
HARDWARE REV F  
END
```

All commands must be terminated with a carriage return e.g the ENTER key .
If this generates the correct response everything is connected properly. If not, try the following.

1. Ensure that the product is on, and that the connections between the computer and product are secure.
2. Try changing the baud rate.
3. You might be able to swiftly resolve the problem by clicking 'Com' and altering the port. If there are a large number of ports, go to Start Menu > Control Panel > System. Open Windows Device Manager to identify the correct port. For older ProScan devices, the correct port should be labelled 'Prior Communications Port'. For more recent PS3 or ES11 devices equipped with FTDI, or connections via a RS232 to USB convertor, the port will be labelled as 'USB Serial Port'. Ensure that this is the port selected.

For older ProScan devices, a cause of a failure to connect could be the drivers not being installed. When first connecting, Windows Device Manager may prompt for the driver. Go to Control Panel > Systems > > Device Manager. Scan for hardware changes, select 'Prior Virtual COM port'. Right click 'Update driver' and select the correct driver. The driver will be located in the 'Prior Scientific' program files as it is automatically included in the Prior Terminal download (C:\Program Files\Prior Scientific\Prior Software (assuming the program is in the C Drive)). Generally, the driver to be selected is the driver for that product, e.g. a ProScan III driver.

(Note that newer versions of the ProScan III should not have this problem as the drivers are bundled with Windows. In the unlikely event that the drivers do not install automatically go to <http://www.ftdichip.com/Drivers/VCP.htm> to download.)

Ensure that this is the port selected by Prior Terminal by clicking the 'Com' button. If this fails to resolve the problem then it is probably the case that the driver is not installed properly. Repeat the above process. If this fails, then please contact Prior Scientific. **Note that Legacy ES9/ES10/PS2 controllers use a Cypress USB chip set that is no longer supported by Windows. It is recommended in this case to use an off the shelf USB-to-RS232 adapter cable.**

Appendix B: Installing a Bar Code Reader

Make sure that the well plate loader is powered off and locate the barcode reader mounting bracket on the plate loader arm.

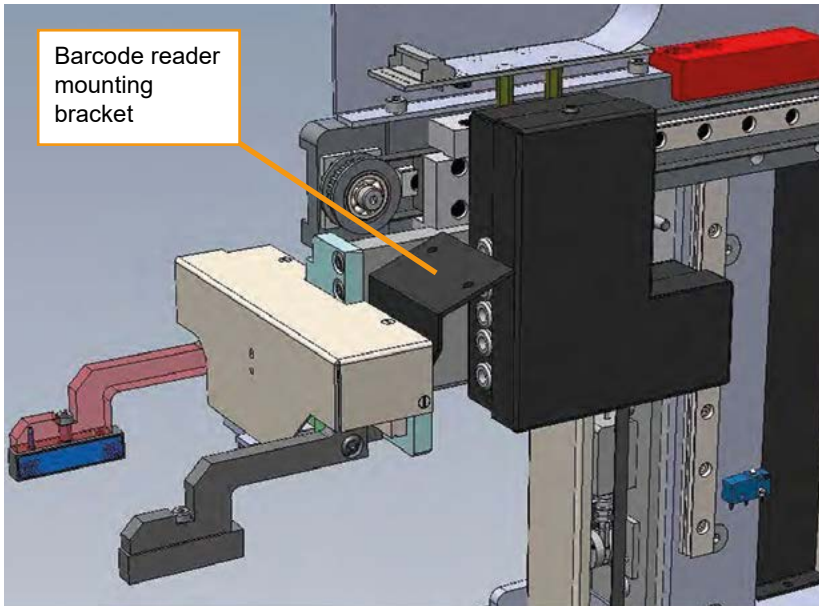

Remove the cover from the Z axis drive box to allow you to feed the barcode reader cable through the cable holes.

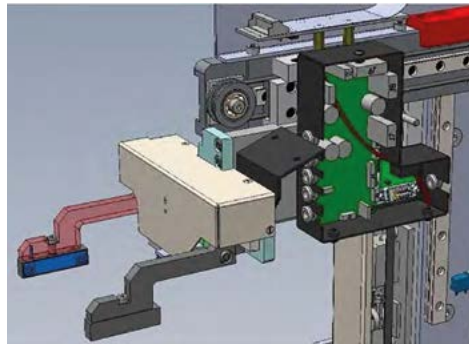
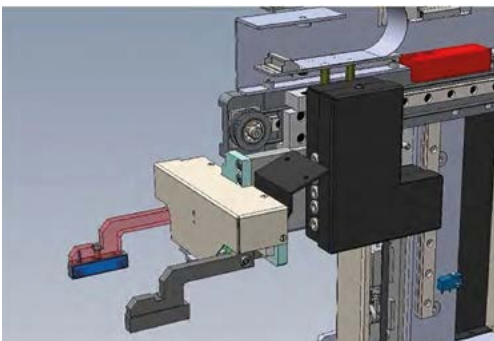

Feed the barcode reader cable through the lower of the cable sockets, through the drive box, and out through the other side.

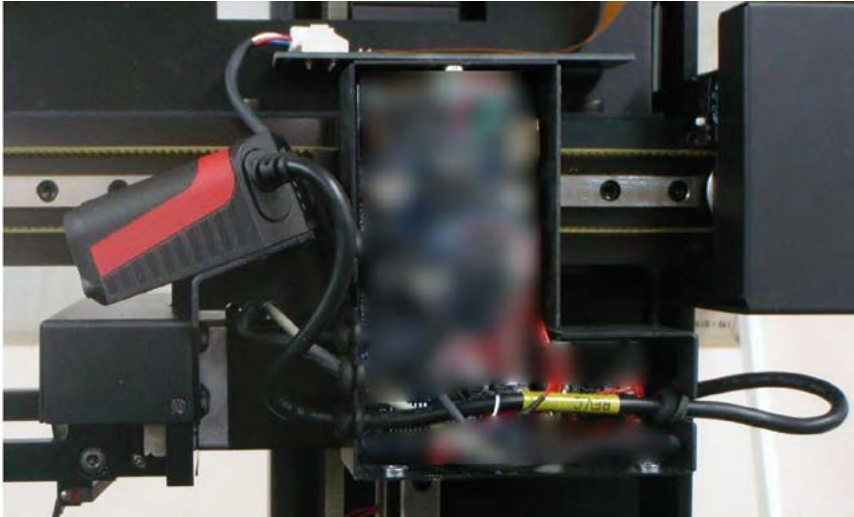

Replace the cover of the drivebox, and plug in the barcode reader to its socket, remembering to make sure that the well plate loader is powered off. The socket to connect the barcode reader is found on the reverse side of the drive box.



Power on the wellplate reader and the barcode reader will now be ready for use.

Appendix C: Using a Barcode Reader

The Barcode Reader helps to fulfil Good Laboratory Practice (GLP) and ensure data integrity by ensuring that captured images are linked to the correct well plate. It decreases the chances of human error leading to images being misattributed.

The Barcode Reader is compatible with a wide variety of commonly used barcode formats. Therefore, if the barcodes are not being read into the system, then please contact Prior Scientific to ensure that the format is compatible with the Barcode Reader.

When the well plate loader is working correctly, the Well Plate Loader Software will display a representation of the hotel with a filled green block to represent an occupied position. If a barcode is present and has been scanned correctly, hovering the mouse over a green block will display the appropriate barcode readout.

It is important that the Bar Codes are placed correctly on the well plates. They should be placed to the left and the barcode can be placed either on, or beneath the lid. However if the barcode is placed under the lid you must make sure the barcode is above the edge of the lid to prevent the shadow of the lid obscuring the barcode.



Above: Correct placement, with no lid

Below: Correct placement, with the barcode above the lid





Above: Incorrect placement

Below: Incorrect placement, with the lid edge partially covering barcode



If the PLW20 system and Barcode Reader have been integrated into non-Prior software, and you are encountering problems, then firstly attempt normal operation using only the Prior Well Plate Loader Software, in order to identify where the problem lies.



For more information please visit www.prior.com

or contact

e: techsupport@prior.com

PRIOR[®]

Scientific

WORLDWIDE DISTRIBUTION



Prior Scientific Ltd
Cambridge, UK

t: +44 (0)1223 881711
e: uksales@prior.com



Prior Scientific Inc
Rockland MA U.S.A

t: +1 781-878-8442
e: info@prior.com



Prior Scientific GmbH
Jena, Germany

t: +49 (0) 3641 675 650
e: jena@prior.com



Prior Scientific KK
Tokyo, Japan

t: +81-3-5652-8831
e: info-japan@prior.com



Prior Scientific China
Suzhou, China

t: +86 (0)512 6617 5866
e: info-china@prior.com