

Video Fiber Viewer™

PRIOR
Scientific

Fiber Optic Inspection System



Operating Instructions

Table of Contents

1. Introduction	2
2. Components	2
3. Getting Started	3
4. Magnification	4
5. Troubleshooting	5
6. Maintenance	5

1. Introduction

The Video Fiber Viewer has been designed and constructed as a robust tool for the inspection of fiber optic terminations in the production environment.

2. Components

The Video Fiber Viewer can be supplied in a number of formats. The main components are:

- Video Fiber Viewer module - available with 10x or 20x objective (a choice of NTSC or PAL video outputs is available).
- Power Supply - combined transformer and cable, for local power supplies throughout the world.
- Monitor (Display Unit) - this may be supplied with the Viewer or purchased locally (a BNC to BNC cable links the Video Fiber Viewer to the monitor).
- Fiber Adapter - this item holds the fiber termination in the correct position for inspection in the Video Fiber Viewer.

Note: For full specifications and part numbers, please refer to the current price lists available from your local Prior Scientific distributor.

3. Getting Started

1. Place the Video Fiber Viewer unit on the workbench, attach the BNC video cable onto the BNC output and insert the power lead into the socket.
2. Unpack the monitor and place in a convenient position. Connect the BNC cable and monitor power cable.
3. Switch on the electrical supply to the monitor and the Video Fiber Viewer.
4. Insert the appropriate connector adapter into the Centering Mechanism of the Video Fiber Viewer. Insert the fiber termination into the adaptor.
5. Rotate the Focus Knob on the top of the Video Fiber Viewer to bring the termination into focus.
6. If necessary, using the Centering Mechanism controls, move the fiber core into the centre of the screen.

***Note:** As the focus mechanism is a continuously elliptical drive, the same focus point can be reached by turning the focus knob in either direction. At some point in the focusing range an image of the LED illuminator will appear which will be displayed as a white diamond or square. Continue focusing until the fiber termination comes into sharp focus.*

4. Magnification

The Video Fiber Viewer fitted with a 20x objective has been designed so that a 125 µm fiber will fill approximately ¾ of the video screen. A Video Fiber Viewer fitted with the 10x objective will have an image of approximately half this size. The final magnification will be dependent on the objective fitted in the Video Fiber Viewer and the screen size of the monitor.

The Video Fiber Viewer will give the following approximate image sizes and magnifications, using a 125 µm diameter fiber.

	Image size (Total Mag.) Approx.	Image size (Total Mag.) Approx.	Image size (Total Mag.) Approx.
	9" monitor	12" monitor	14" monitor
Video Fiber Viewer with 10x objective	47mm (376x)	63mm (504x)	73mm (584x)
Video Fiber Viewer with 20x objective	95mm (760x)	127mm (1016x)	148mm (1184x)

The Video Fibre Viewer has a 'Back-Light' facility incorporated into the Centering Mechanism. This is the small illuminated aperture adjacent to the Adapter Holder. The fiber core will be illuminated if the other end of the fiber is placed into this aperture.

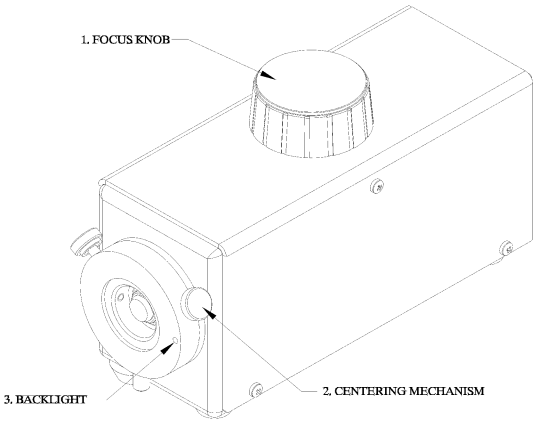

5. Troubleshooting

If no image appears on the screen please check that:

- The monitor or Video Fiber Viewer is switched on or connected.
- The BNC to BNC cable is correctly connected.
- A fiber termination is placed in the appropriate adapter and is fully located in the Centering Mechanism.
- The surfaces of the LED and the termination may be seen during the focussing process. The termination surface will move as the controls on the Centering Mechanism are adjusted (the surface of the LED will not move).

6. Maintenance

The Video Fiber Viewer should be virtually maintenance free. However, it is possible for some contamination to occur. Dirt or dust can accumulate on the front surface of the optics, which may appear as small particles on the monitor screen. These particles could be mistaken for scratches, pits or contamination on the fiber end.

Dirt or dust can be removed by gently wiping the optics with a lens cleaning tissue or soft cloth with a gentle solvent such as alcohol. Inappropriate cleaning material or vigorous cleaning may damage the optics.

The LED illuminator has a projected life of 10,000 hours. For replacement of the LED, decontamination of the optics and other major problems, the system should be returned to Prior Scientific, or your local dealer.

For more information on Prior Products visit our web site at www.prior.com

Specification subject to change without notification

Part No. W2690 Issue 1.0 07/01

8-8736

VISIT PRIOR ON THE WEB AT www.prior.com
Specifications subject to change without notice.