

Table of Contents

1.	Important Safety Information	2
2.	Product Description	4
3.	Unpacking the System	7
4.	Installation	10
5.	Getting Started	16
6.	LF100K Keypad.	18
7.	RS232 Commands	23
8.	I/O connectors	33
9.	Principles of Operation	36
10.	Suggested settings for tuning	38
11.	Troubleshooting	49
12.	System Specifications	51
13.	Glossary of Terms	Section 9 54
14.	Returns and Repairs	Section 11 57
15.	Appendices	Section 12 60

1. Important Safety Information

Important Safety Information

- **Do not expose the product to water or moisture.**
- **Do not expose the product to extremely hot or cold temperatures.**
- **Do not expose the product to open flames.**
- **Do not allow objects to fall on or liquids to spill on the product.**
- **Do not touch the glass plate fitted between the circular dovetail and the top plate. Any dust, dirt, fingerprints will cause degradation of image quality**
- **Do not poke anything inside the open aperture in the base plate of the unit. There are delicate optical components which are easily damaged if touched.**
- **WARNING. This unit emits visible laser light from the aperture in the base plate of the unit. The total continuous power does not exceed 1mW thus it falls into a CLASS 1 Laser Product. As such the user should not stare directly into the laser beam although the normal eye reflex response will offer protection. The laser power is less than most commercially available laser pointers sold in novelty shops.**
- **DANGER. Under no circumstances unscrew the lid off the unit. The unit contains a CLASS 3B visible laser diode with a maximum continuous power of 35mW. This laser power is only accessible with the unit dismantled and should only be performed by Authorised Service Centres. Disassembly of the unit will void the warranty. This product does not contain user serviceable components.**
- **Use only the power supply included with this unit. Failure to do so could instantly destroy the electronics and laser diode. The unit requires +5VDC at 3Amperes.**
- **Always switch off the unit using the on/off rocker switch or unplug the PSU when plugging/unplugging any peripherals. Failure to do so may result in damage to the unit.**

2. *Product Description*

Product Description.

The Prior Scientific Laser Auto Focus Module model LF210 is a very advanced, integrated unit which combines a visible laser diode, associated optical components and detectors, electronics with on-board micro controller which outputs analogue and digital signals suitable for controlling piezo or motor focus drives. The analogue output voltage can be inputted directly into the Prior NanoScan piezo Z stage controller. If the employment of Prior stepper motor is preferred then the Prior keypad with integral stepper motor drive unit (Prior LF100K) is needed. It is a simple procedure to add the unit into the optical path of many popular laboratory microscopes using infinity corrected optics, attach the Prior focus motor (Prior H122) to the fine focus knob of the microscope and connect the motor to the LF100K. The laser beam passes through the microscope objective onto the sample. The detection circuitry in the LF210 monitors the spot position on the sample and continuously servos the focus motor or piezo stage to keep the spot position static thus ensuring optimum visual focus is maintained at all times.

The LF210 is best suited to metallurgical and semiconductor examination using incident illumination where the sample has a reasonably flat, reflective surface. It is not suitable for maintaining focus on biological slides.

Using the LF100K keypad allows full stand alone operation. The micro controller that is built into LF210 allows the unit to act as an intelligent motorised focus controller in addition to its primary task of automatic focus control. The closed loop action can be disabled, manual focus achieved using the integral rotary digipot and remote focus control can be implemented by connecting the RS232 communication port of the unit to a host p.c.

The 2 essential requirements required for correct operation of LF210 are as follows:-

- Microscope must have infinity corrected optics (Infinity corrected objectives used in conjunction with tube lens.) The ∞ symbol will be engraved on the objective barrel.**
- It must be possible to insert LF210 in the collimated region of the microscope optics. This is the region between the objectives and the tube lens.**

- **The LF210 is designed to be used in bright field only. It will not work reliably when using alternative contrasting techniques such as DIC or Dark Ground.**

3. Unpacking the System

Unpacking the System

Each Laser Focus system will consist of the following:-

Component	Component Description
A	Model LF210 Laser Focus Module
B	Appropriate set (top/bottom) of dovetail flanges for a particular Make/Model of microscope. (see below)
C	Model LF100K Control Pad/stepper drive. This is mandatory if stepper motor focus drive is being implemented but optional when used with piezo drive since the LF210 can be controlled entirely from a p.c. (RS232 communication)
D	Model H407 desktop PSU +24V at 60VA. This is plugs into LF100K and provides power for the H122 stepper motor.
E	Model H122 Focus Drive with correct clamping ring (see below)
F	Model W3299 desktop PSU +5VDC at 20VA. to power LF210

Dovetail flanges.

These come as a pair and will be factory fitted to the top/bottom halves of the LF210 unit to fit the correct microscope manufacturer/model number.

Focus Clamping ring.

These fit within the H122 Focus adapter and are made to clamp over the coarse focus knob of the particular microscope.

Note: Make sure that all of the components that should be included with your LF210 System have been supplied. If parts are missing please contact your local Prior Dealer.

Take great care when unpacking the LF210 unit; in particular do not touch the glass plate in the lid of the unit or poke any object into the aperture in the base. This could cause catastrophic failure of the unit or significant loss of performance.

4. *Installation*

Installation

Mechanical Installation of H122 Focus Motor

- Loosen the clamp screw on the focus motor assembly and remove the focus motor from the focus adapter (fig.1)
- Loosen the 3 socket set screws around the periphery of the focus adapter using a 2mm Allen wrench until the focus sleeve is able to fit inside the adapter. Note that it is important to insert the sleeve in the correct orientation with the lip furthest inside the adapter (the chamfered edge of the sleeve will be inserted first). Note the orientation of the sleeve as it has a recess around its outer surface, which will hold the sleeve in when the set screws are tightened. This recess must line up with the tips of the socket set screws. (See fig.1).
- With the sleeve in place, tighten the 3 socket set screws in sequence until they all just touch the sleeve, ensuring that the split in the sleeve does not line up with any of the set screw positions. **DO NOT TIGHTEN UP ANY OF THE SET SCREWS AT THIS STAGE.**
- Push the adapter onto the preferred coarse knob of the microscope as far as it will go. The preferred side is normally the left side of the microscope (as viewed by the operator) since H122 will then not interfere with the drop down controls of the stage which are often found on the right hand side of the microscope. The inside fitting diameter of the sleeve is designed to be slightly larger than the coarse knob, provided the set screws have not been tightened and are compressing the sleeve.
- While holding the adapter in place, tighten the set screws in sequence only enough to secure the unit onto the coarse focus knob. The focus knob will have to be rotated to gain access to all of the screws.
- Check that the unit has been tightened sufficiently by taking hold of it and turning it. If the adapter is correctly fitted it will stay attached to the coarse knob.
- Slide the focus motor into the adapter as far as it will go and while applying gentle pressure to the motor tighten the clamp screw. This will hold the motor in place.

The rubber drive bush on the end of the motor spindle should now be pressing against the end surface of the fine focus control knob. This can be confirmed by manually rotating the exposed fine focus knob on the opposite side of the microscope and feeling for the resistance caused by the detent positions of the stepper motor as it rotates. This will not cause any damage to the focus motor

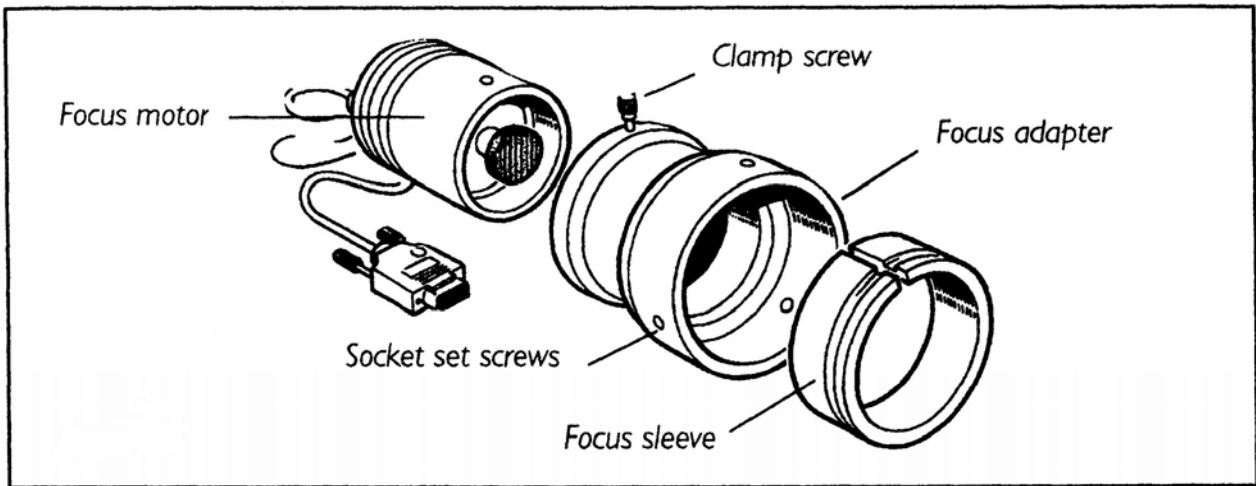
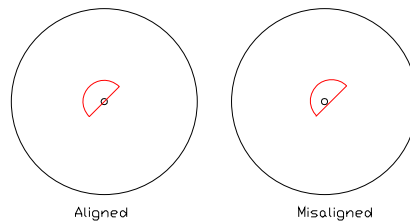

Figure 1

Installation of LF210

- **Some microscope have a detachable incident illuminator placed between the nosepiece and the binocular head, other manufacturers have the incident illuminator integral with the nosepiece (i.e. they cannot be separated.)**
- **In the case of the former design remove the binocular head from the nosepiece using the Allan key provided by the microscope manufacturer and place it to one side. Fit the Laser Focus to the microscope using the same Allan key. Orient the LF210 so that the front of the unit faces the front of the microscope.**
- **Screw in the Prior alignment jig into a spare location of the microscope nosepiece. If none are free then remove one objective to fit the jig.**
- **Check that the on/off rocker switch at back of LF210 is off (green band on switch is not visible). Plug in W3299 power supply unit (PSU) and connect W3299 to mains socket.**
- **Plug Null Modem cable into RS232 socket (if desired). Prior Scientific offers this cable as an optional accessory (H276). The other end of this cable should be plugged into an RS232 Com port of a p.c. (running Windows 98/2000/XP)**
- **Switch on LF210 using rocker switch on at back of unit. The STANDBY/SERVO led will be yellow. If it does not illuminate then there is still now power applied to LF210**
- **A semi-circular red laser beam should be seen falling onto the jig . This is most conveniently seen by placing a mirror or other flat reflective surface on the stage so that the observer can see the reflection of the jig and laser beam in the mirror. It is often possible to use the sample which the user wishes to use if it is sufficiently flat and reflective.**

- The aim is to adjust the position of the semicircle so that the middle of straight edge of the semicircle coincides with the 1mm hole in the jig (this is the optical axis of the objective lens.) If the alignment is not correct then steer the laser beam to the correct position by inserting the 1.5mm long reach Allan key supplied into the apertures marked 0DEG and 45DEG. Care is need to insert the alan key vertically



down through the aperture since it has to locate into the head of a grub screw and it is possible to miss it. Small adjustments of one or both settings will move the laser beam to the correct position.

- Remove jig and, if necessary replace the objective lens.
- Fit illuminator/binocular unit to top flange of LF210 using the same 1.5mm Allan key.
- Ensure that the dovetail fittings are secure. If the dovetail fittings do not fit then check the part numbers for the dovetail fittings (Section 3). In the second case then the LF210 unit has to be placed between the binocular head and the illuminator/nosepiece (which cannot be separated). In this instance remove the binocular head and insert LF210 between binocular head and illuminator/nosepiece using the same procedure as described above.
- It is preferable to place the LF210 unit between the illuminator and the nosepiece due to the fact that the laser light does not then pass through the illuminator beam splitter with a resultant attenuation in the detected signal. Typically therefore LF210 will receive stronger reflected light in this configuration (for a given surface reflectivity).

- **Select 50X objective and achieve a best focus on a typical sample surface (flat and reflective) in the usual manner by using the coarse and fine focus knobs. Even if the H122 focus motor is attached provided no power is applied to this motor (rocker switch at back of LF100K is off) it is safe to operate the fine focus knob manually.**
- **Run Windows Hyperterminal application (appendix a) to set up a communication between the LF210 and host computer. Successful communication between LF210 and p.c. is confirmed when pressing the Enter key <cr> returns 3 numbers.**
- **Type “TEST, 1” The LF210 will output 3 numbers ten times per second. The first number is (A-B), second number is calculated spot position and third number is (A+B.) (A+B) should be 2000 (approximately). This confirms that there is the correct intensity of laser light being reflected off the sample and falling on the sensor.**
(A-B) is the Difference and will be within the range +/-3000. Use a flat bladed screwdriver to adjust the height of the sensor (marked SENSOR) to bring this number to a position in the range +/-50. Note that if (A-B) is saturated at +3000 then turn the screwdriver anticlockwise and visa versa
Use the digipot to move the focus either side of best focus and observe (A-B) going either side of zero. The unit is now mechanically set up correctly.

5. *Getting Started*

Getting Started (LF210 with LF100K and H122 stepper motor)

Having installed LF210 correctly it can now be attached to LF100K.

Temporarily switch off LF210 using rocker switch

Ensure that rocker switch at back of LF100K is off.

Connect LF100K to LF210 using the 2 flying leads. The 8 way Mini-Din plugs into the socket marked KEYPAD and the 15 way D type plug fits the Socket marked OUTPUT.

Connect +24V desktop PSU to 3 pin socket at back of LF100K. Connect PSU to mains using mains lead supplied.

Switch on the power to H122 motor using the rocker switch on back panel of LF100K

Switch LF210 back on.

The H122 motor will not move significantly so the image should still be in focus. There may be a small shift in focus which can be corrected by using the digipot. Use the digipot to confirm that it is correctly mounted and driving the focus as it should. The focus motor will mimic the rotation (i.e. speed and direction) of the digipot. If this is the case then the unit is configured correctly. If this is not the case then undo the focus motor from the focus adapter to see whether the motor itself rotates. If the motor is not responding to the digipot then see Section 11 (Troubleshooting)

The next section describes the operation of the LF100K in greater detail.

6. *LF100K Keypad.*

LF100K Keypad

Using the KeyPad (LF100K)

The LF100K Keypad has two flying leads, both of which plug into LF210. The LF100K requires power to drive the stepper motor which is provided by the +24VDC 60VA desktop PSU which plugs into the back. It allows standalone operation of the system and also incorporates stepper motor drive circuitry to allow the OUTPUT of LF210 to drive Prior H122 stepper motor. The basic functions it offers are as follows:-

- Rotary digipot offers remote motorised operation of the fine focus of the microscope when SERVO key is not active
- Allows optimum servo response for any magnification objective using Objective Select keys 1 to 9

With the LF210 installed as per Chapter 4 then follow the following procedure:-

- Write the objective magnification on the buttons marked 1-5. The buttons have clear plastic snap in tops with white inserts. It is suggested that the lowest magnification is the lowest number button e.g. 5x, 10x, 20x, 50x, 100x are buttons 1,2,3,4 and 5. Start by rotating the nosepiece until the x20 objective is in place. Press the key corresponding to this magnification. This now will associate all subsequent settings to this objective.
- Use the digipot to focus on the specimen.
- Press the TARGET button. This establishes this as the target best focus position that the module will servo to. It is not the target Z position since this will change with stage movement for a sample with differing height or with tilt.
- The initial set up for that objective is now complete. Further configuration (electrical servo gain KP and damping KD) may need to be done by connecting the module to a p.c. using Hyperterminal (see section ?)
- Use the rotary digipot to move the focus slightly away from best focus. Press the SERVO key. The STANDBY/SERVO led on the side of LF210 should change from yellow to green. The focus motor should rotate a small amount (the amount it was

moved away from focus) to bring the image back to best focus and then stop. Be prepared to turn SERVO off by pressing the SERVO button again should the motor not stop at best focus. It is possible for the focus motor to race off continuously or oscillate. If the former happens the user should reverse the sign of KP, if the latter happens the magnitude of KP should be reduced. This has to be done by sending RS232 command from the p.c. through Hyperterminal. The value of KP needs to be adjusted so that the response is quick but not liable to oscillate. Start with small value of KP and increase in increments. Remember to use SAVE command to store the optimum value of KP to non-volatile memory otherwise the new value will be lost on power down.

The table below describes the function of each key.

Note that FUNCTION+KEY works as follows:-

- a. Press FUNCTION key. LED will flash indicating its active.
- b. Release FUNCTION key then press appropriate key.
- c. This completes the action. Note that the FUNCTION key then becomes inactive (indicated by its led going out)

The exception to this operation of FUNCTION/UP and FUNCTION/DOWN which increases/decreases buzzer volume respectively. Here FUNCTION key is kept pressed whilst repetitively pressing UP/DOWN key FUNCTION key is cancelled afterwards by pressing it again.

Key	Operation
-----	-----------

Key	Operation
1 to 5	<p>Selects the optimum parameters for the particular objective.</p> <p>The following parameters are associated with each objective and are normally pre-set using the RS232 communication with p.c. and/or using keystrokes with the FUNCTION key (see below).</p> <p>The pre set parameters for each objective are TARGET,KP,KD(see RS232 Commands)</p>
SERVO	<p>Switches on and off the SERVO or Auto Focus function.</p> <p>STANDY/SERVO LED goes green when SERVO is active.</p> <p>Switching SERVO off enables the Digipot. The LF210 will also then function as an intelligent motorised focus drive controlled using commands sent along the RS232 connection (if fitted to a p.c.)</p> <p>SERVO/STANDBY mode of LF210 is also indicated by the LED's on the front of LF200</p>
UP	With unit in STANDBY holding UP button will cause focus to move up continuously at a speed set by the SPEED button.
DOWN	With unit in STANDBY holding DOWN button will cause focus to move down continuously at a speed set by the SPEED button.
SPEED	With unit in STANDBY each successive momentary depression of this button will cycle the speed at which the focus moves using UP/DOWN buttons or Digipot through 100%/25%/50%. The preferred setting is stored even through a power cycle. This button will change the speed setting whether motor is moving or stationary. The unit must however be in STANDBY.
HOME	Moves stage to a preset HOME position.
TARGET	Use the digipot to establish best visual focus. Pressing this key will set this as the focus point that will be maintained during SERVO action for the specific objective lens.
FUNCTION/UP	Keeping FUNCTION key pressed whilst repetitively pressing UP key increases volume of buzzer.
FUNCTION/SPEED	Switch Laser on/off by holding the FUNCTION key and pressing the SPEED key at the same time.

Key	Operation
FUNCTION/DOWN	Keeping FUNCTION key pressed whilst pressing DOWN key increases volume of buzzer. Note that minimum volume is the buzzer switched off.

7. *RS232 Commands*

It is possible to control the LF210 using a selection of ASCII commands that are transmitted from the host computer to the laser focus unit via the serial RS232 interface using Hyperterminal. For details of how to configure Hyperterminal see Appendix A.

All commands are terminated with a Carriage Return code <cr>

Commands are separated from arguments by one or more of the following delimiters.

COMMA

SPACE

TAB

EQUALS

SEMICOLON

COLON

Thus to move the focus UP by 100 steps the user could enter any of the following

U,100<cr>

U 100<cr>

U:100<cr>

U;100<cr>

U100<cr>

Proof of successful acceptance of any command sent to LF210 is the response '0'<cr>. The response is immediate i.e. it does not wait.

Commands can be stacked (queued) although they are not necessarily acted upon immediately e.g. sending a move command U,1000 immediately followed by PZ,0 will zero the Z position after the Up move has finished.

If a command is not valid a response of "E,n" is returned. The n specifies an error type as listed below. The error codes are the same as for Prior Scientifics other motor controllers (ProScan and OptiScan)

ERROR CODE	ERROR DESCRIPTION
2	NOT IDLE
3	
4	STRING PARSE
5	COMMAND NOT FOUND
7	
8	VALUE OUT OF RANGE
10	ARG1 OUT OF RANGE
11	ARG2 OUT OF RANGE
12	ARG3 OUT OF RANGE
13	ARG4 OUT OF RANGE
14	ARG5 OUT OF RANGE
15	ARG6 OUT OF RANGE

Commands specific to LF210 operating as Auto Focus unit.

Command	Arguments	Response	Comments
Config			Reports currently selected configuration
Config	K N S H		Allows the user to select a pre-defined configuration that should be close to optimum for their particular set up; K = OEM setting for large travel (1000µm) piezo stage with no internal height sensor N = For use with the Prior NanoScan stage with internal height sensor in closed loop mode S = For use with Prior H122 stepper focus drive and LF100K (This is the factory default setting) H = Open loop height sensor. Output voltage on pin 3 of 15 way socket is error voltage (proportional to DELTA) This voltage is unaffected by KP,KI,KD,DELAY,DELAYDRATE. Use GAIN command to change sensitivity. GAIN,D will disable Error Output (clamps it to 0V) GAIN,E will enable Error Output
KP		G	Reports proportional gain (g) value
KP	G		Sets proportional gain to value (g). This value balances stability and speed of response. Typical values are 20-200, factory default is 100 range is +/- 2000.
KD		D	Reports differential gain (d) value
KD	D		Sets differential gain value (d). Differential controller is used to stabilize the output signal. It predicts the future state of the system using the current rate of change of values. This rate is assumed to continue which allows overshoot to be predicted and cancelled out. The differential value is multiplied by the KD constant value. Increasing this value from zero will reduce the overshoot as the focus approaches best focus. If the opposite happens then enter negative values. It is found that using LF210 to control H122 stepper motor or Prior NanoScan piezo stage the default value of zero is optimal. Default is 0. Working range is +/- 1000
KI		I	Reports KI value (I)
KI	I		Sets Integral Gain value (I). Integral gain is the sum of all previous error signals multiplied by a gain constant and fed out to the drive. The integral term becomes very large and so is multiplied by small numbers for use in the system. This command is used to set and read the gain constant, which gets divided by 65000 for use in the system. In most instances this can be

			ignored by setting it to zero. Default is 0. The working range is +- 1000.
RATE			Displays DAC Slew Rate (r)
RATE		r	Sets DAC Slew Rate (r). The Slew rate of the Digital to Analogue Converter (DAC) that is used for output to the piezo can be controlled by the user. This can prevent oscillation of the system around focus, which makes the image appear to flicker. This command is used to set and read the maximum slew rate. Thus a value of 1 means that each DAC output (Range -2047 to +2047) can only change by a maximum of 1. Each DAC output is every 1msec. Thus the slew rate of the output voltage is limited.
DELAY			Displays the Servo Delay Setting (D)
DELAY	D		Sets the Servo Delay Setting (D). The Servo loop is run every 1ms, this command can be used to reduce the run rate of the loop, and this may be needed if the piezo focus drive is slow to respond. The default value is set to 0. A complete set of 16 bit ADC reads (ADC0 ADC1 ADC2 ADC3 CalcPos CalcError CalcDiff SetPiezo) takes 1msec, each individual ADC read takes 0.1msec.. Time is the number of additional 0.1msec delays inserted inside each ADC read and so increases this time. Thus DELAY,10 increases ADC read from 1msec to 2 msec DELAY,90 increases ADC read from 1msec to 10msec. PID calculations are carried out immediately after each ADC read. In most instances this should be set to zero. Default is 0
DELAYD			Reports the Dynamic Delay Setting (D)
DELAYD		D	Sets the Dynamic Delay (D). Dynamic Delay. This a another Delay setting Dynamic Delay is dependent on the error (Target Position-Calculated Position). For large error (DELTA) the delay uses this value. In most instances this should be zero. Default delayd,0
TARGET			Displays the Target Position (s) last set for a particular objective.
TARGET		S	Sets the target focal position for an objective.
DELTA			Returns the error between target laser spot position and measured spot position (Target, S will set this to zero)
LASER			Reports currently set laser intensity
LASER		I	Sets laser intensity to I (I to 4095). Default is 2000.
LASER		D	Disables Laser, useful for capturing an image without visible laser spot.
LASER		E	Enables Laser.
OBJ		O	Selects the current objective and all settings associated with it (O = 1 to 6)
OBJ		O,M	Sets Objective magnification and associated KP value (KP set to 2500/m)
PIEZO			This command is used to change the analogue PIEZO voltage on pin 3 of the 15 way socket which controls the piezo position. The command should only be used in mode 2. With no arguments the current absolute value is read

		<p>back, if the step argument is included the value is changed by the step specified. This command works in conjunction with OUTPUT,n,m command as follows:-</p> <p>Switch LF210 on.</p> <p>The unit will be in MODE,2 (standby)</p> <p>OUTPUT,0,4000 This sets PIEZO voltage range 0V to +4V. The current value will be midway viz +2V</p> <p>PIEZO Returns 0</p> <p>PIEZO,2047 Sets PIEZO voltage to 4.000V</p> <p>PIEZO Returns 2047</p> <p>PIEZO,-2047 Sets PIEZO voltage back to 2.000V</p> <p>PIEZO Returns 0</p> <p>PIEZO,-2047 Sets PIEZO voltage to 0.000V</p> <p>PIEZO Returns -2047</p> <p>PIEZO,2047 Sets PIEZO voltage back to 2.000V</p> <p>PIEZO Returns 0.</p> <p>Another example</p> <p>OUTPUT,-10000,10000 This sets PIEZO voltage range -10V to +10V. The current value will be midway viz 0V</p> <p>PIEZO Returns 0</p> <p>PIEZO,2047 Sets PIEZO voltage to 10.000V</p> <p>PIEZO Returns 204</p> <p>PIEZO Returns 0.</p> <p>It is important to note the following:-</p> <p>Do not connect PIEZO voltage output to the device which is to be driven until it is established that the voltage range is limited to the voltage range for the device. Failure to do this could damage the piezo drive circuitry.</p> <p>Output voltage is generated from a 12 bit DAC therefore full voltage range is 4095 steps.</p> <p>Thus for OUTPUT,0,10000 gives 2.44mV per step.</p> <p>Reading PIEZO returns an absolute position (+/-2047) whilst PIEZO,n is a relative step move.</p> <p>In MODE,2 only PIEZO,n command or moving digipot will change PIEZO voltage.</p>
INFOCUS	1 or 0	<p>1 = in focus, 0 = out of focus</p> <p>It is in focus when (SpotPosition - Target) is within +/- FOCUS Value See FOCUS Command. INFOCUS led will go green and INFOCUS(L) TTL output will go low.</p>

FOCUS		N	<p>Defines the range (n) which focus can drift from the target value before triggering a servo move.</p> <p>n is the +/- value deviation from TARGET (DELTA) before the object is deemed to no longer be at a satisfactory focus. The servo algorithm works in the following way. Imagine another window +/-0.5n either side of target. During pull-in in MODE1 servo will continue until (Spot Position-Target) (DELTA) is < +/- 0.5n then SERVO will stop. SERVO will only be activated if Error > +/-n and will stay active until again <0.5n. Thus Servo is activated when ERROR > +/-n but deactivated when < +/-0.5n. In this way the spot serves well within +/-n.</p> <p>INFOCUS is 1 when Error < +/-n INFOCUS is 0 when Error > +/-n INFOCUS led will go green and INFOCUS(L) TTL output will go Low when error is smaller than this value. INFOCUS led will flash yellow when error is larger than this value.</p>
INHIBIT		N	<p>n is the value of (A+B) viz light Intensity on sensor at which the Calculated Error will be forced to zero. Thus the output voltage freezes(MODE,1), voltage falls to zero (MODE,0) or output pulses stop (stepper motor) It should be noted that due to AGC action this Inhibit will occur sooner if the target (A+B) value is high (e.g. LASER,4000). For a low LASER value (e.g. LASER,500) as the spot goes out of focus the laser can increase intensity to keep (A+B) at 500 and only when the laser is at its maximum permissible intensity will (A+B) begin to fall.</p> <p>The INFOCUS led will switch to red colour and INFOCUS(L) output will go low when (A+B) falls below this value.</p> <p>Default 250</p>
ININHIB			<p>Inhibit status. Returns 1 if state is in INHIBIT, 0 if not (normal operation) TTL output will be INHIB(L) See INHIBIT above.</p>
MODE		Mode	<p>This command sets or reads the operating mode.</p> <p>For Piezo control there are 2 modes to use, mode 1 is servo enabled, and mode 2 is open loop/standby control. MODE,0 is only used if the user wishes to use the unit as a height sensor in open loop mode in which case the unmodified error signal is read (see section below for operation in MODE,0)</p>
OUTPUT		Vmin,Vmax	<p>This sets or reads the minimum and maximum error voltage (pin 3 of 15 way socket) in units of mV</p> <p>e.g. OUTPUT,-4000,4000 reduces error voltage between +/-4V OUTPUT,0,10000 reduces error volts to 0-10V</p> <p>Note that this cannot be unipolar and negative e.g. OUTPUT,-4000,0 is not allowed.</p>
POS			<p>This reads the spot position on the sensor. This is $65535 \cdot (A-B)/(A+B)$</p>

SAVE			Saves parameters from volatile memory into non-volatile memory. Any changes between SAVES will be lost with a power cycle.
LOAD			Loads the parameters saved in non-volatile memory back into working memory. (see SAVE)
LIST			<p>Lists all user settable values associated with the current objective. List ends with END which should be used to identify end of LIST (so additional lines can be added)</p> <p>Note that this command should be preceded by the correct objective required using OBJ,n</p> <p>e.g.</p> <pre> VERSION 027 OBJ 4 KP 100 KD 500 KI 0 RATE,1 DELAY 200 DELAYD 0 LAG,1 LASER 2000 INHIBIT 250 FOCUS 5000 OFFSET 0 0 MODE 2 REFLECT 0 END </pre> <p>LAG,OFFSET and REFLECT have no relevance here.</p>
VER			Returns 3 digit version number of software e.g.026
DATE			Returns 3 digit version number of software e.g.026
ADC			<p>Returns (A-B) , Reflectance, (A+B)</p> <p>These three values are measured simultaneously.</p> <p>This command may be useful to the user for diagnostic purposes.</p>
S			<p>Returns Calculated spot position , (A+B), DELTA</p> <p>These three values are measured simultaneously.</p> <p>This command may be useful to the user for diagnostic purposes</p> <p>For instance the user can carry out the following sequence:-</p> <pre> MODE,2 Move to best visual focus TARGET,s Set Current spot position to Target </pre>

			<p>PIEZO,-1000 Move stage down by 1000 steps</p> <p>S Read (A-B), Calculated spot position, (A+B)</p> <p>PIEZO,1 Move stage up by 1</p> <p>S</p> <p>loop 2 steps above.</p> <p>User has (A+B) and DELTA which can be plotted against height(PIEZO)</p> <p>A note of warning.</p> <p>The user should be aware that PIEZO,n changes the voltage input to the piezo stage. Prior NanoScan piezo stage has its own integral height sensor and operates in closed loop mode such that input voltage (0-10V) and mechanical position are accurately related. If the LF210 is inputted to a piezo stage which has no internal feedback the relationship of voltage input to mechanical position will be inaccurate and show substantial hysteresis therefore PIEZO voltage is not represent the accurate mechanical position.</p>
KEYPAD		0 or 1	This enables (1) or disables (0) KEYPAD . This will be saved after SAVE command.
TTL		0 or 1	Setting TTL,1 will enable TTL inputs. TTL is set back to 0 at every power up. In MODE1/2 TTL,1 will enable TTL inputs whose functions are defined in the TTL section below.
RESET			Returns firmware to same state as factory. i.e. same as when the software is first loaded. It is important to be aware that all parameters changed by the user and saved to non-volatile memory (using SAVE) will be lost.
TEST		l,n	This displays (A-B), Calculated laser spot position and (A-B) every n milliseconds. n is optional and the default is 100msecs. This command is normally not useful for applications but is a useful diagnostic when setting unit up. The numbers can be displayed using Windows Hyperterminal Utility offered with most versions of Windows.

Commands specific to LF210 operating as Height sensor unit.(MODE,0)

The LF210 is primarily a sensitive height sensing unit which is used in conjunction with Prior NanoScan Piezo Z stage, Prior LF100K/H122 focus stepper motor drive or a DC motor drive in a closed loop mode.

The user establishes best visual focus using the digipot and types TARGET,s<cr> when in MODE,2 (see table below) This enters the Calculated laser spot position as the Target position. The user then types MODE,1 and LF210 will then control the piezo stage or stepper motor to maintain the TARGET laser spot position (maintain best visual focus)

It should be noted that the LF210 does not need to have a linear relationship between Calculated Spot Position and Actual height for this to work. The Calculated Spot Position just has to be sensitive and drift free.

If the user chooses to read Calculated Spot Position (or DELTA) from LF210 and control the focus mechanism themselves then this option is allowed by setting the unit in MODE,0.

The important difference between MODE,0 and MODE,2 is that for the former the analogue ERROR voltage will be proportional to DELTA and NOT be affected by any of the KP,KD,KI settings. The DELTA value will be updated every 1 millisecond. The proportionality factor can be changed using the GAIN command.

MODE		Mode	This command sets or reads the operating mode. For Piezo control there are 2 modes to use, mode 1 is servo enabled, and mode 2 is open loop/standby control. MODE,0 is only used if the user wishes to use the unit as a height sensor in open loop mode in which case the unmodified error signal is read (see section below for operation in MODE,0)
OUTPUT		Vmin,Vmax	This sets or reads the minimum and maximum error voltage (pin 3 of 15 way socket) in units of mV e.g. OUTPUT,-4000,4000 reduces error voltage between +/-4V OUTPUT,0,10000 reduces error volts to 0-10V Note that this cannot be unipolar and negative e.g. OUTPUT,-4000,0 is not allowed.
POS			This reads the spot position on the sensor. This is $65535 \cdot (A-B)/(A+B)$
TARGET			Displays the Target Position (s) last set for a particular objective.
TARGET		S	Sets the target focal position for an objective.
DELTA			Returns the error between target laser spot position and measured spot position (Target, S will set this to zero)
GAIN		N	Set as/returns the GAIN value (N) between the DELTA value and the analogue Error V _{olate} on pin 3 of the 15 way output socket. This is effectively a sensitivity value for use as a height sensor.
GAIN		D	Disables the Error Output. It is clamped to zero.
GAIN		E	Enables the Error Output. It is clamped to zero.
SAVE			Saves parameters from volatile memory into non-volatile memory. Any changes between SAVES will be lost with a power cycle.
LOAD			Loads the parameters saved in non-volatile memory back into working memory. (see SAVE)

Commands specific to LF210 operating as motorised focus controller

Note SERVO must be disabled (i.e. be in MODE0 or MODE1) for LF210 to operate as an intelligent motor controller responding to commands sent along the RS232 port.

Command	Arguments	Response	Comments
Z			Sets absolute motor position to zero
GZ	N		Moves to absolute position n
M			Moves Z motor back to zero position
VZ	N		Moves the motor at constant velocity n pulses per second
\$		1 or 0	Returns motor status (1 = moving 0 = stationary)
PZ			Returns motor position
SSZ	N		Prior HI22 focus motor , when driven from LF100K keypad has 50000 steps per revolution. If the user wishes to scale the moves than this command multiplies the move command by this number and outputs that number of steps. e.g SSZ,1 GR,50000 Motor rotates 1 revolution. SSZ,10 GR,50000 Motor rotates 10 revolutions.
C	N		Sets the step size (n) when using U and D commands.
U	N		Moves the motor up by n steps (step size defined by C command)
D	N		Moves the motor down by n steps (step size defined by C command)
ZD	N		Reverses the direction of the motor when instructed to move. This can be used to always allow positive values for KP,KD for correct servo action. n= +1 or -1 Default ZD=1
SMZ	n		Sets the maximum rotational velocity of motor to n. Units are % Range 0-100% Default 50%
SAZ	N		Sets the acceleration of motor to n. Units are % Range 0-100% Default 50%

8. I/O connectors

OUTPUT connector is High Density (3 Row) D type socket.

.Pin number	Signal Type	Input/Output	Range/comments
1	GND		
2	Sum	output voltage	0-10V
3	Piezo pos/error	output voltage	Defaults to 0V-4VDC (OUTPUT,0,4000) but can be changed using OUTPUT command. In MODE,2 the output voltage is midway between Vmin and Vmax at power-up and can be altered using the PIEZO,n command.
4	Position	output voltage	Proportional to Calculated spot position. Range is +/-5V
5	GND		
6	Pulse	TTL Output	Outputs pulses at a rate proportional to ERROR. Used to control stepper motor drive in LF100K
7	n/c		
8	n/c		
9	n/c		
10	Dir	TTL output	Used with Pulse to determine direction of drive for stepper motor.
11	n/c		
12	n/c		
13	+5V output		
14	In Focus(L)	TTL Output	InFocus flag (see INFOCUS command)
15	Inhib(L)	TTL Output	Inhibit flag (See INHIB command)

Notes

2) Intensity. This is (A+B) and is a purely analogue signal (A and B are rectified and added) i.e. it does not go through any ADC/DAC conversion

3) Mode 1/Mode2 this is piezo output voltage .Mode 0 converts voltage to Error Voltage proportional to Spot position error). Output voltage range set using Output command.

6) Pulse output. MODE,1/MODE,2 should be used for this. e.g if OUTPUT,0,4000 then piezo voltage sits at 2.000V.

However setting TARGET and then MODE,1 will output up/down pulses to maintain spot position at Target position.

Note that the pulse rate will be affected by the KP,KD,KI values in the same way as the analogue output voltage on pin

3

TTL inputs.

Unit has 4 TTL inputs using the 8 way Min-Din socket. The contact assignment is as follows:-

Any user wishing to use these TTL inputs can obtain a suitable cable from Prior Scientific (Prior part number W1867)

These inputs are inactive by default.

Use command TTL,I to activate these inputs

Use SAVE to ensure that they are active for all subsequent power ups

These inputs allow control of LF210 without needing to use the RS232. The response to these inputs will be faster than sending the same commands via RS232.

Contact	Cable wire colour	TTL numbering.	
1	black	TTL2	
2	white	+5Vout	
3	red	TTL4	MODE 1(H)/MODE 2(L)
4	yellow	A(encoder 0Deg)	
5	purple	TTL1	
6	blue	0V	
7	green	TTL3	LaserOn(H)/Off (L)
8	brown	B(encoder 90Deg)	

TTL1 and TTL2 select the objective as below.

TTL1	TTL2	OBJ
0	0	1
0	1	2
1	0	3
1	1	4

9. Principles of Operation

The LF210 relies on the knife edge principle.

Half the aperture of the collimated light is blocked. The diagram below shows how this spoils the symmetry of the optical system about the optical axis. The collimation of the laser beam is adjusted to be the same as the objective lenses so that the best visual focus and the laser focus coincide. Moving the focus either side of focus not only defocuses the laser spot but moves laterally on the sample surface.

The reflected light retraces the path of the incident beam, 50% reflecting off a beam splitter through a focussing lens onto a duo lateral silicon position sensor. The image falling on the position sensor is effectively the same as seen by the camera viewing the sample.

The position sensor has 2 electrodes. The spot generates current from each electrode A and B. If the spot is in the centre $A=B$. The sum $(A+B)$ is proportional to light intensity. If the spot moves to the right B increases and A decreases (say).

$$\text{Spot position} = K(A-B)/(A+B)$$

$$\text{Light intensity} = C(A+B)$$

Where K and C are proportionality constants.

$(A + B)$ is created using summing amplifier to give voltage proportional to intensity.

$(A - B)$ are created using difference amplifier.

SUM $(A+B)$ and DIFFERENCE $(A-B)$ voltages above are simultaneously read by high precision 16 bit DAC every 1msec.

Range of Sum = 0V-10V = 0-32768

Range of Difference = +/-10V = +/-32768

Calculated Position = (DIFFERENCE * 65536) /SUM

Target Position can be set by reading Current Calculated Position.

Calculated Error = Calculated Position – Target Position.

Analogue Error Voltage = (Calculated Error * Gain)/10000

If Analogue Error Voltage exceeds +/-2047 then value is set to +/-2047.

Background light/current leakage which would result in voltage offsets are measured on power up prior to the laser being switched on. As a result it is important to ensure that all covers of unit are in place before power up.

Microprocessor calculated spot position using the formulae above.

LF210 has 3 test routines which may be useful during installation and fault diagnostics.. These tests are enabled using a Terminal Emulation program such as Windows Hyperterminal and enables the user to constantly read the values during installation. The TEST can be stopped by typing TEST,0 or a power cycle..

Note that an optional second parameter can be used to determine time interval between print outs (time units are milliseconds)

TEST	0		stops all test reports.
TEST	1,delay		returns Difference (-4095-+4095),Calculated Position (+/-200000) and Sum (0-4095) every 1/10 second. Difference = A-B Sum = A+B Position =65535*(A-B)/(A+B) Delay is optional and specifies the delay time in milliseconds between displays. Default is 100.
TEST	3		Returns a Calculated Error (DELTA). This is Calculated Position – Target Position. With no Target Position entered or TARGET,0 entered then Calculated Error = Calculated Position.
TEST	6		Calculated Position, Reflectance, Laser Intensity

10. Suggested settings for tuning

The user should first configure LF210 for the type of drive connected to the 15 way output socket using the CONFIG command. This sets parameters which should be most suited to x50 objective and should work for lower power objectives but at low response speed. The parameters are initialised to be the same for all Objectives (see OBJ command)

One technique to improve servo response is as follows:-

In MODE,2 (open loop) run TEST,1 with image at best focus. Confirm (A-B)=<+/-500. Use mechanical adjustment of sensor to achieve this. Type TEST,0 to stop test.

Type TARGET<cr>

Type MODE,1

If unit runs off then type MODE,2.. It is likely that KP needs to be reverse sign (positive feedback)

If focus oscillates then reduce KP

Adjust KP,KD,RATE,DELAY to achieve fastest response without flicker or oscillation. This can be tested by either pushing down on the stage or manually adjusting the coarse focus whilst looking at the image. At best the LF210 will respond quick enough for the image not to go out of focus. Be aware that Prior NanoScan has limited travel (+/-100 microns or +/-200 microns) so focus correction can only be within this range.

- CONFIG,s

For LF100K and HI22 stepper motor connected to fine focus of microscope (100 microns per revolution.

Remember to type SAVE so that LF210 will power up in their configuration.

The default settings are shown and suggested settings for each objective. Note the following:-

Parameters shown in **bold** should be the first to be adjusted if further improvement is required.

High values of KP will show oscillation, small values will show slow response. As a rule of thumb use ratios for KP which are the inverse of square of the ratio of magnifications i.e. $KP(x50)=4*kp(x100)$

FOCUS value determines how far from best focus before servo action is initiated. It is a dead band either side of best focus. Too small a value will show constant corrections which will be seen as a flicker of the image. Too large a value will result in the image being able to go too far out of best focus before corrective action.

Parameters shown in *italics* should be left alone and will have no effect on servo behaviour.

Parameter	default	x5	x10	x20	x50	x100
kp	50	4000	4000	200	50	20
kd	0					
ki	0					
<i>rate</i>	<i>/</i>					
<i>delay</i>	<i>0</i>					

<i>delayd</i>	<i>0</i>					
<i>lag</i>	<i>1</i>					
<i>laser</i>	<i>2000</i>					
<i>inhibit</i>	<i>500</i>					
focus	8000	1000	2000	3000	8000	8000
<i>offset</i>	<i>0,0</i>					
<i>mode</i>	<i>2</i>					
<i>reflect</i>	<i>0</i>					

- **Config,n**

For pin 3 of 15 way output socket (Piezo Output) connected to 0-10V voltage input of Prior NanoScan

Parameters shown in **bold** should be the first to be adjusted if further improvement is required.

High values of KP will show oscillation, small values will show slow response. As a rule of thumb use ratios for KP which are the inverse of square of the ratio of magnifications i.e. $KP(x50)=4*kp(x100)$

Rate determines how quickly the Output voltage can change. Since the depth of field of low power objectives is high the Rate needs to be higher for the servo action to correct for large focus shifts.

Delay is set to zero for high power objectives otherwise the user can observe the delay due to the small depth of field.

FOCUS value determines how far from best focus before servo action is initiated. It is a deadband either side of best focus. Too small a value will show constant corrections which will be seen as a flicker of the image. Too large a value will result in the image being able to go too far out of best focus before corrective action.

Parameters shown in *italics* should be left alone and will have no effect on servo behaviour.

Looking at the graphs below showing the sensitivity of the LF210 for different objectives it is clear that it is most sensitive for high magnifications., therefore kp can be reduced.

Parameter	default	x5	x10	x20	x50	x100
kp	100	2000	1000	1000	100	25
kd	500					
ki	0					
rate	5	200	100	50	5	5
delay	0	200	200	200	0	0
<i>delayd</i>	<i>0</i>					
<i>lag</i>	<i>1</i>					
<i>laser</i>	<i>2000</i>					
inhibit	500					
focus	8000	1000	2000	3000	8000	8000
<i>offset</i>	<i>0,0</i>					
mode	2					
<i>reflect</i>	<i>0</i>					

Depth of field

Prio NanoScan is a very sensitive Z stage and can be used as an accurate Z positioner when used with LF210 in MODE,2 (open loop)

OUTPUT,0,10000 will set Piezo voltage range of LF210 0V-10V which is 0-100 micron travel of NanoScan

PIEZO command can be used to move the NanoScan with an absolute position range 0-4095, thus having a theoretical resolution of 0.025microns.

PIEZO command can be used to step the sample position until the observer sees the image just going out of focus.

The DOF is the +/- range within which the image is not observed to be going out of focus.

FOCUS value is typically half the value at which INFOCUS flag stops toggling. Thus the FOCUS value will ensure that the image stays well within the DOF in MODE,I

	x5	x10	x20	x50	x100
NA	0.1	0.25	0.4	0.75	0.9
DOF(+/-microns)	12.0	2.5	1.25	0.4	0.1
FOCUS	1000	2000	3000	8000	8000

Graphs below show representative behaviour using a reflective wafer as a surface.

Prior NanoScan is used to move the sample +/-2047 counts either side of best focus (+/-50 microns)

Green trace is (A+B)

Red trace is Calculated Spot Position.

The cursors show the approximate Z range of linear behaviour of the Calculated Spot Position .

Note that correct servo action is possible provided Calculated Spot Position does not cross zero.(This would result in positive feedback)

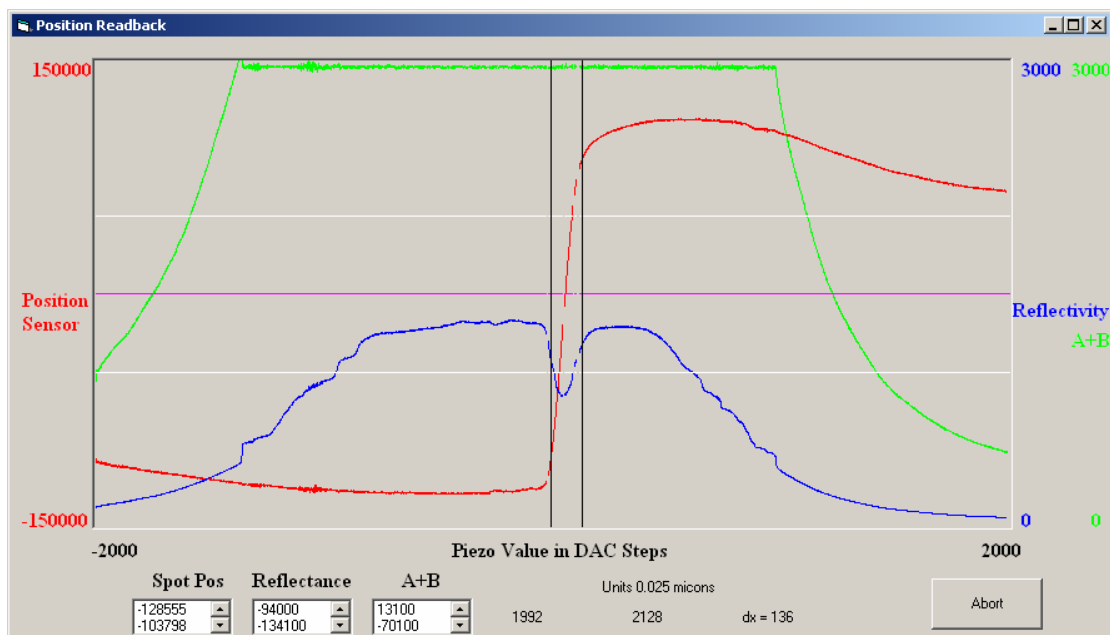

X100 Linear range is +/- 1.7 microns

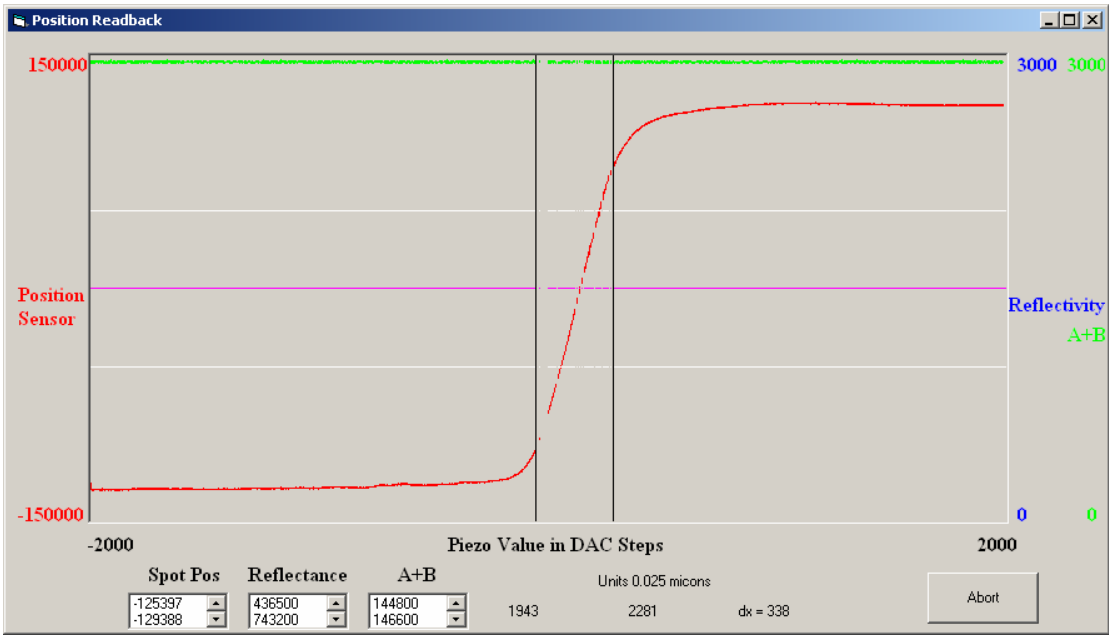

X50 Linear range is +/-4.2 microns

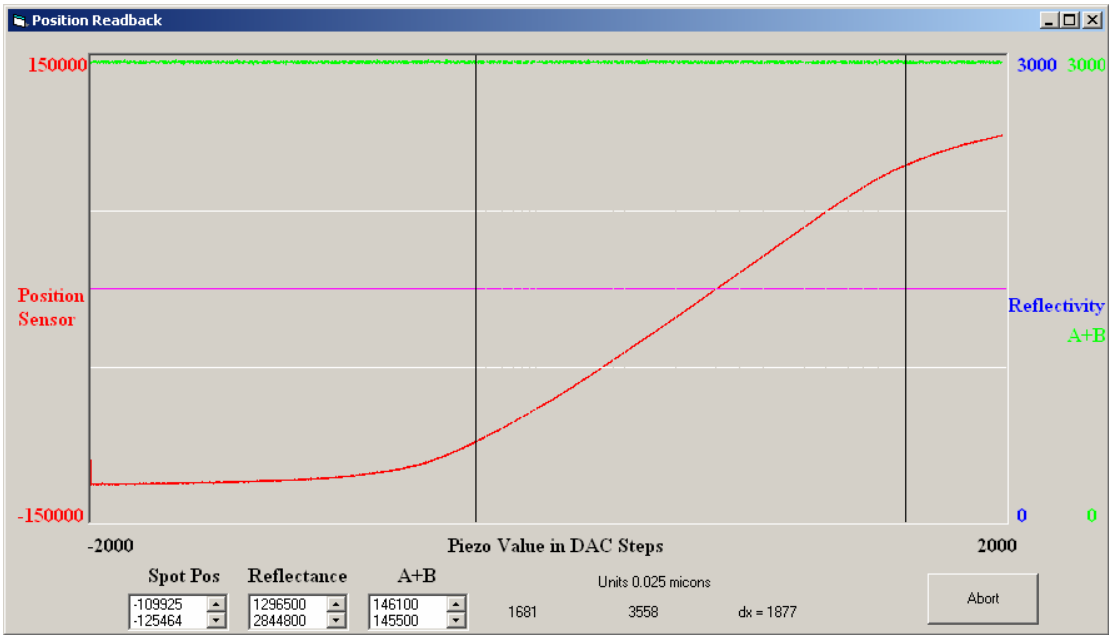

X20 Linear range is +/-23.0 microns

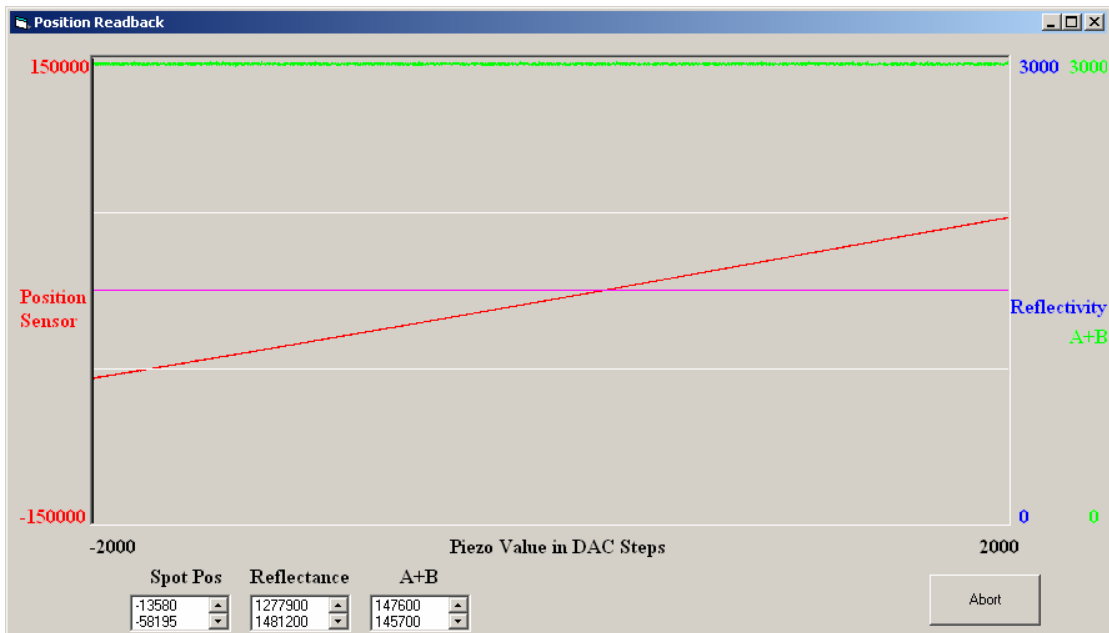

X10 Linear range > +/-50 microns

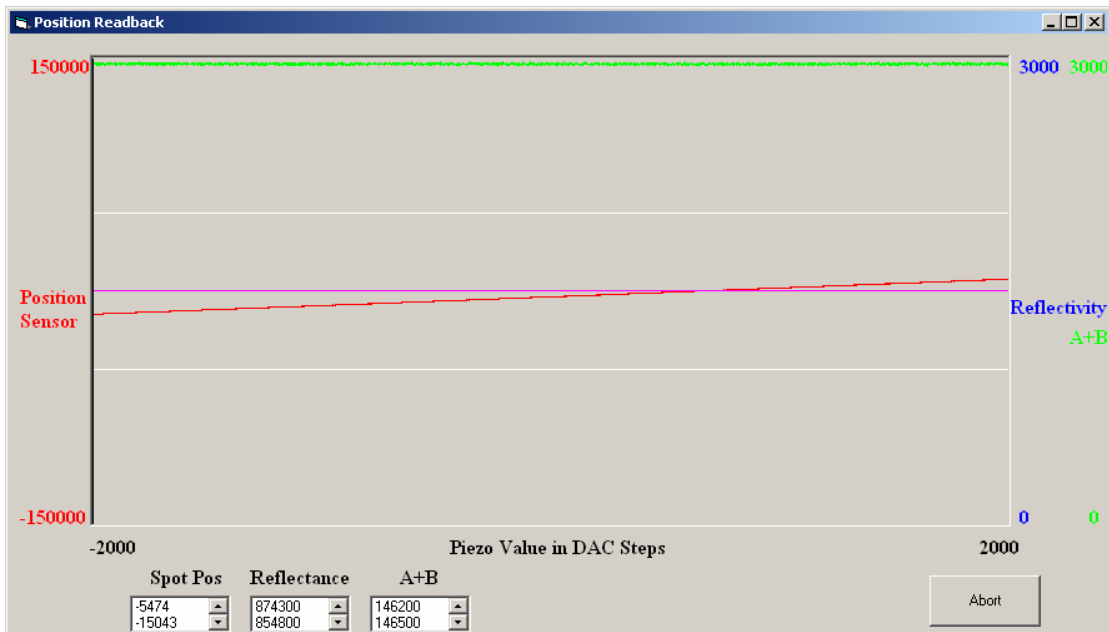

X5 Linear range > +/- 50 microns.

Graphs below show the dynamic behaviour of the unit.

All settings (see LIST ?) are as shown above.

The sample is moved +50 microns and set to MODE,1 (servo) and the servo dynamics captured.

MODE,2

The sample is then moved -50 microns and then set to MODE,1

Blue trace is the PIEZO voltage

Red Trace is Calculated Spot Position

Dual yellow lines show FOCUS value either side of TARGET within which unit is considered to be in focus.
 Magenta trace is the INFOCUS flag.

It can be seen that x5,x10 and x20 objectives come into focus <200msecs
 x50,x100 pull into focus <500msecs.

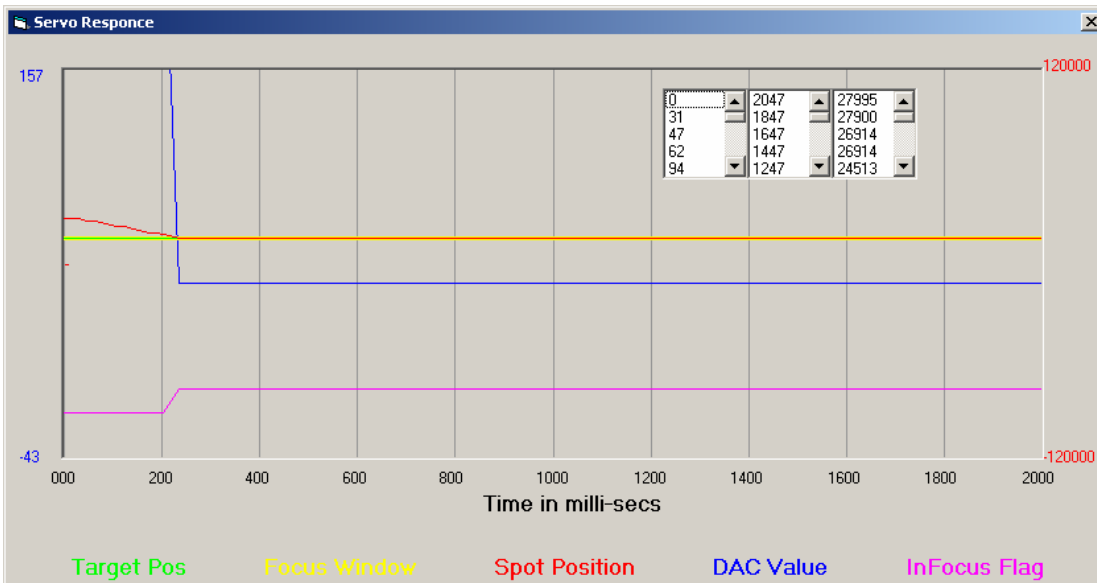

X5 PIEZO,2000

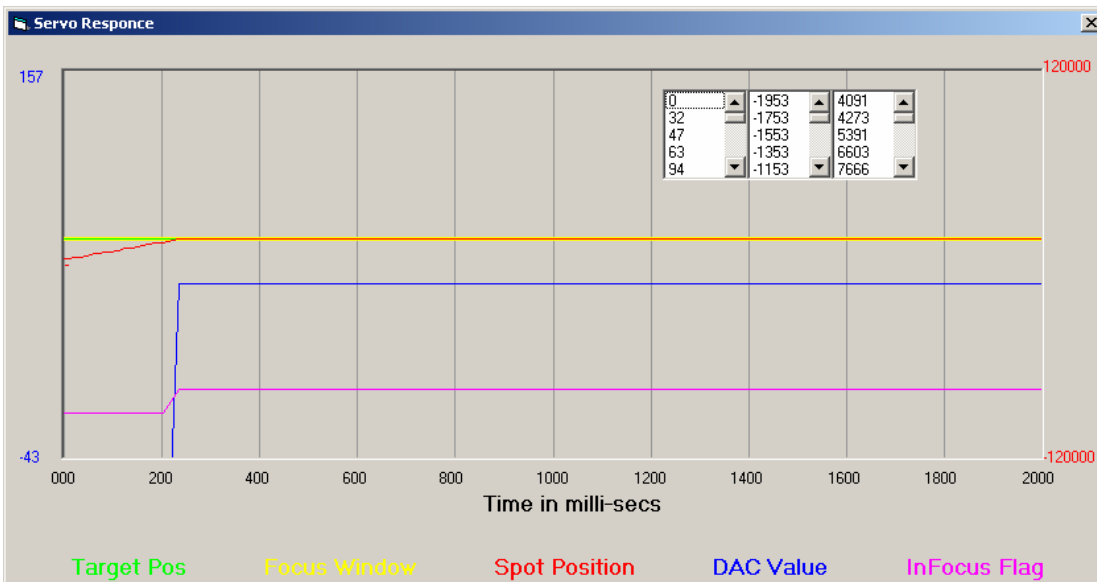

X5 PIEZO,-2000

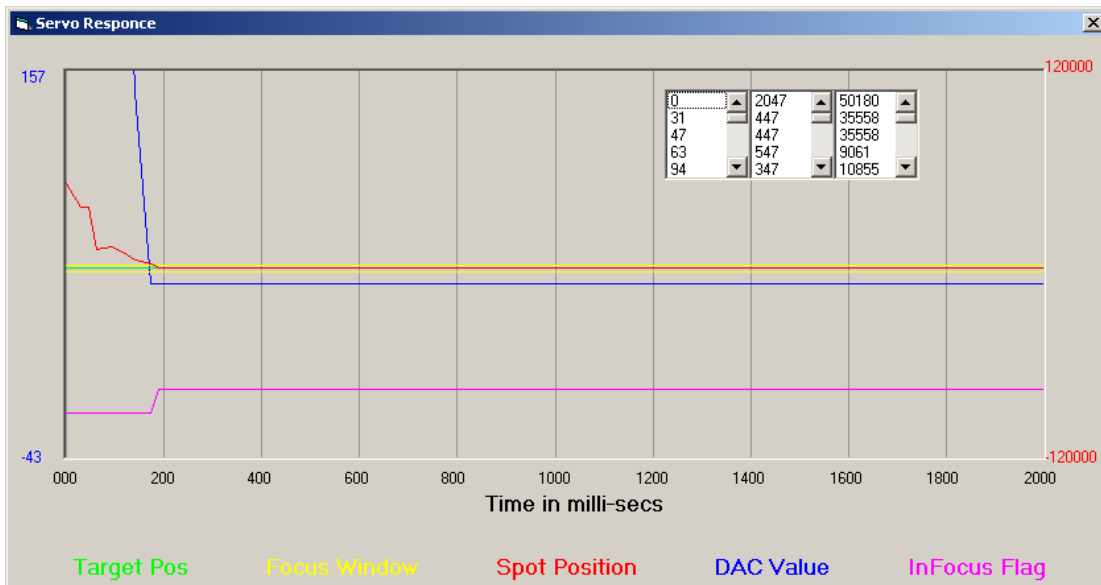

X10 PIEZO,2000

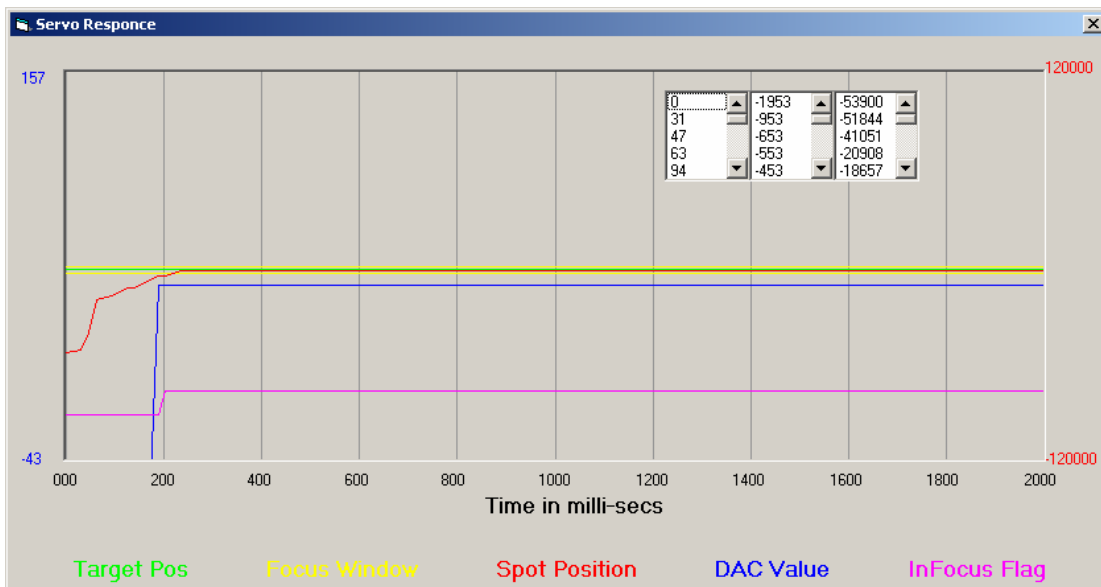

X10 PIEZO,-2000

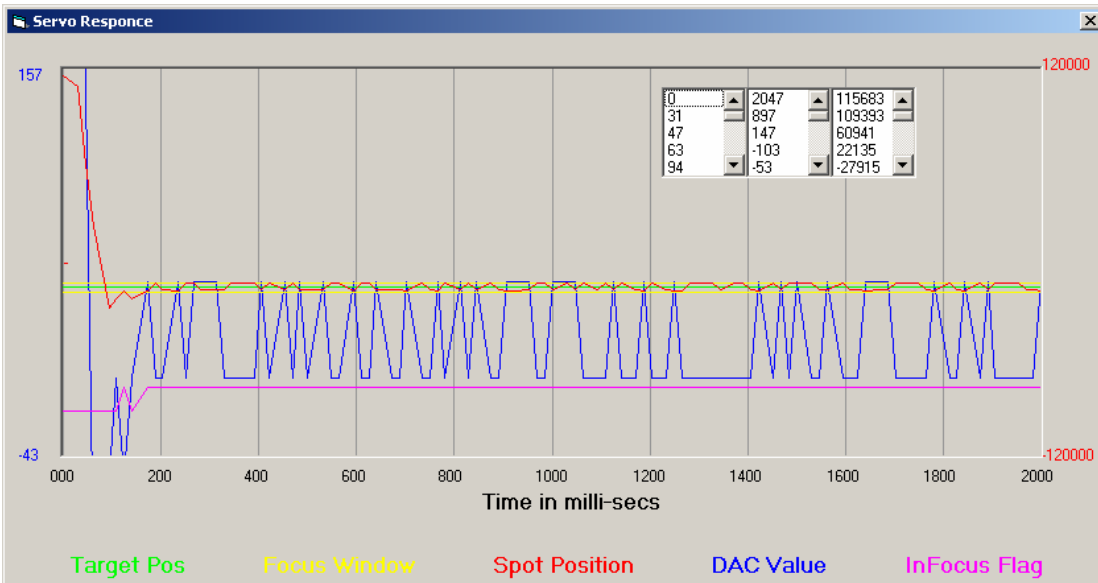

X20 PIEZO,2000

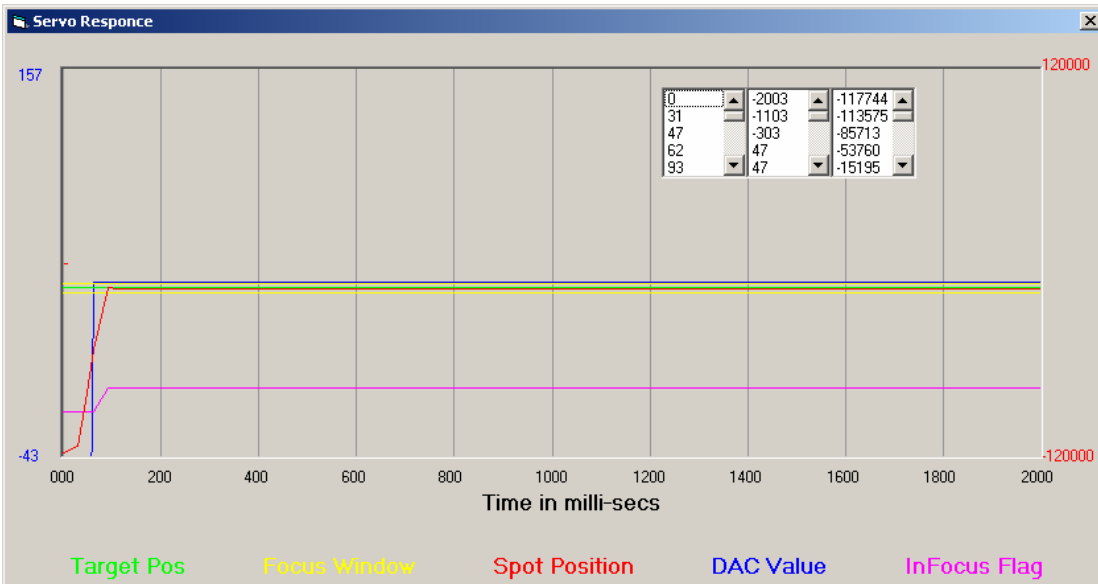

X20 PIEZO,-2000

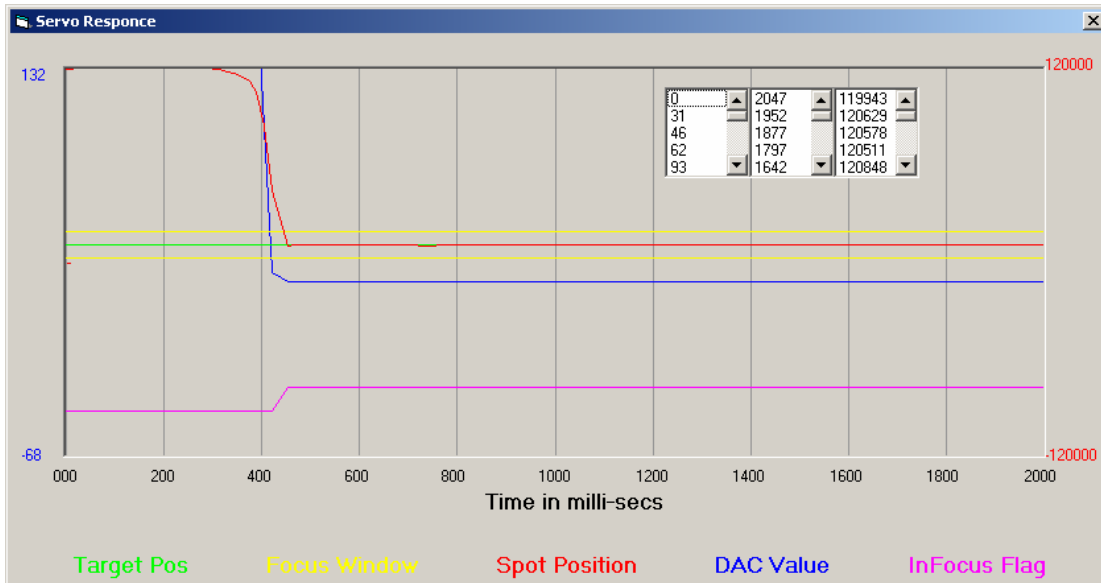

X50 PIEZO,2000

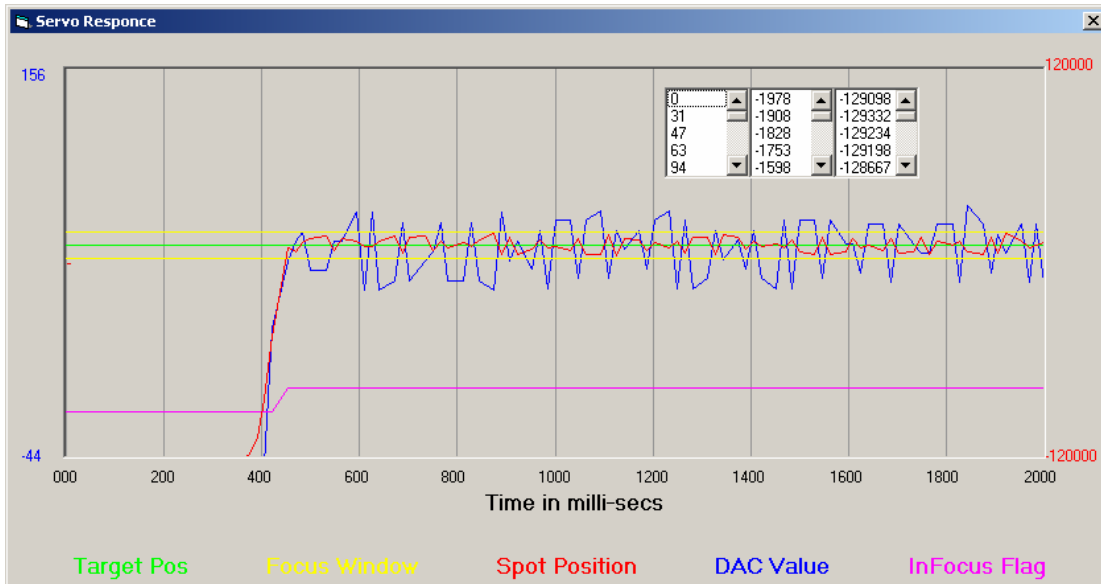

X50 PIEZO,-2000

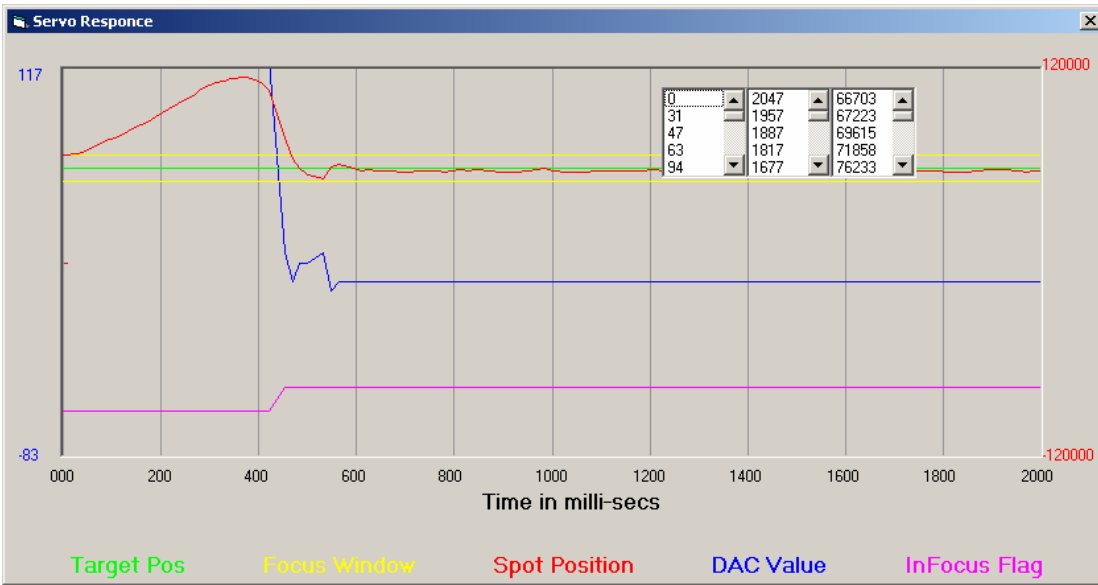

X100 PIEZO,2000

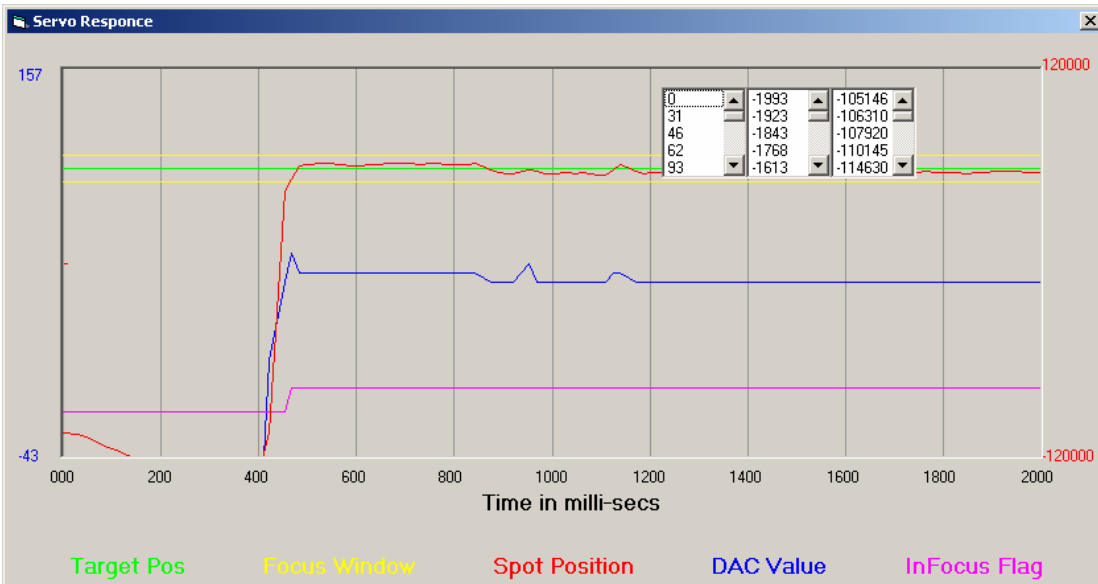

X100 PIEZO,-2000

11. Troubleshooting

Troubleshooting

Problem:

LF210 is totally inactive when switched on using the rocker switch. The green led of the power supply is not lit.

Suggestions:

Check that the mains socket used by the PSU is live (plug in another electrical appliance). Check the fuse in the mains plug (if present), or alternatively replace mains cable with another which is known to work with another appliance. Pull out the 2.5mm socket from (LF210) to see if unit is shorting out the output of the PSU. If the led on the PSU remains off then it is likely that PSU is faulty and needs replacement.

WARNING

Replace +5V 35W PSU with genuine Prior replacement otherwise permanent damage can be done to LF210

Problem:

The unit is totally inactive when switched on using the rocker switch. The green led of W? PSU is on.

Suggestions:

The DIGIPOT led should be on when power is applied to the unit. If no led is lit then the unit has no power. Although the green led of PSU is on it may be that the PSU is still faulty. Switch PSU off by removing the mains. Reapply mains power to PSU. If fault persists then return complete system back to Prior.‘

12. System Specifications

System Specifications

Power

Universal integral power supply (for LF210 Laser Focus unit)

Input: 90 - 265V 110 - 240V, 50/60Hz 15VA

Output: 5VDC 20VA

Universal integral power supply (for LF100K Keypad with integral stepper motor drive)

Input: 90 - 265V 110 - 240V, 50/60Hz 15VA

Output: 24VDC 60VA

Specifications subject to change without notice.

Glossary of Terms

Section 9

Glossary of Terms

Aperture - The area which is available for the passage of light

Autofocus - The ability of a Z focus system to automatically find the correct focus

Coarse Focus Knob - The large knob on the side of a microscope that moves the stage up and down relatively large distances with relatively small motion.

Controller - The device which provides positional control to the stage, focus drive, filter wheel, or shutter.

Digipot - A circular device/encoder, typically mounted on a joystick used to manually rotate the fine focus knob. The digipot rotates the focus knob at an angle relative to the angular movement of the rotation of the digipot.

Encoder - A feedback device which provides positional information for either an XY stage or the focus drive assembly. Encoders can either be rotary or linear.

Fine Focus Knob - The small knob on the side of the microscope that moves the stage up and down relatively small amounts with relatively large movements. Typically 100 microns per revolution of the fine focus knob.

Flash Memory Capability - The ability of the Prior controller to download new software without requiring an EPROM change. This ability is analogous to that of a solid state hard drive.

Focus Drive - A motor and adapter assembly that typically mounts to the coarse focus knob of a microscope and drives the fine focus knob.

Hyperterminal - A terminal emulation program provided with Windows 95,98 NT. Instructions for setting up Hyperterminal to communicate with the Prior controller are located in the appendices.

Incident Illumination - Light which falls on the object from the same direction as viewing.

Inverted Microscope - A microscope that views the object from below. The objectives are underneath the stage.

Open Loop System - A control system that has no means of comparing the output with the input for control purposes. Open loop stage systems rely on the controller to send the proper amount of pulses to the motor to achieve the required movement.

RS-232 - A communication standard which specifies electrical, mechanical and functional characteristics for serial binary communication circuits in a point to point link. Commands from a computer's COM port travel to the controller via RS-232.

Serial Control - A type of information transfer where the bits are handled sequentially

Stepper Motor - A motor which when current is applied generates a holding torque. The motor is rotated by switching the coils on and off. The step motors in Prior stages and focus motors generally have 200 steps per revolution, which is then microstepped to 50,000 microsteps per revolution.

TTL - Transistor-Transistor Logic. An integrated circuit with its inputs and outputs directly tied to transistors. Inputs and outputs are low voltage (<1 VDC) and high voltage (>3 VDC).

Transmitted Illumination - Light which passes through the object

Upright Microscope - A microscope that views the object from above

XYZ - The term used to describe the axes of a microscope that move left/right(X), front/back(Y) and up/down(Z)

Returns and Repairs

Section 11

Returns and Repairs

Should you experience problems with your ProScan System and want to send it back for service, warranty or otherwise, a Return Material Authorisation (RMA) number must be obtained from the appropriate Prior Scientific office before returning any equipment. For North and South America contact Prior Scientific Inc. and for the rest of the world call Prior Scientific Instruments Limited on the telephone numbers shown below.

<p>Prior Scientific Instruments Limited Units3/4 Fielding Industrial Estate Wilbraham Road, Fulbourn, Cambridge, England, CB21 5ET Telephone +44(0)1223 881711 FAX +44(0)1223 881710 email:uksales@prior.com</p>	<p>Prior Scientific Inc. 80 Reservoir Park Drive, Rockland, MA 02370-1062 USA Telephone 781 878 8442 FAX 781 878 8736 email: info@prior.com</p>
--	--

How to Run HyperTerminal

Instructions for using Windows HyperTerminal Emulation Program for communication to Prior Controller.

- 1) Click Start, then Programs, then Accessories, then HyperTerminal.
- 2) Select the “HyperTerminal” icon.
- 3) In the “Connection description” dialog box enter filename e.g. prior, select an icon and press OK.
- 4) In the “Connect to” dialog box enter Phone Number (if required) and Select COM1 or COM2 as appropriate and press OK.
- 5) Enter the following parameters in the Port Settings box ;

Bits per second	115200
Data bits	8
Parity	None
Stop bits	1
Flow control	None

- 6) Press OK button.
- 7) Select File, Properties and Settings tab.
- 8) Press ASCII Setup...
- 9) Select “Echo typed characters locally” and “Append line feeds to incoming line ends” (you should find that “Wrap lines that exceed terminal width” has already been selected).
- 10) Press OK
- 11) Press OK.

**MAXIMUM OUTPUT @ 690nm <1mW
CLASSIFIED TO BS EN 60825-1:1994**



CLASS 1 LASER PRODUCT

LF210 is a Class I Laser Product emitting laser light at a power less than 1mW as a collimated beam 6mm diameter. The wavelength is 680-695nm.

As such the product is safe to use without eye protection. However it is normal safe practice to avoid removal of LF210 from the microscope without first disconnecting it from its PSU

Never point the laser beam directly into the eye (look into the source of the laser beam)

**CAUTION - CLASS 3B LASER RADIATION
WHEN OPEN AND INTERLOCKS DEFEATED
DO NOT STARE INTO BEAM**

LF 210 contains a high power laser diode. The laser diode emits up to 35mW continuous power (CW) at 680-695nm . The laser emits visible light. As such this is a Class3B laser product. The LF210 is assembled using tamper proof screws and an interlock which removes power from the laser when the lid is removed from the base.

UNDER NO CIRCUMSTANCES should an unqualified person attempt to remove the lid from the base of this product. This could render the product as a laser hazard. This can only be done by a qualified Prior Scientific Engineer who has training in assembly and repair of laser products.

Appendix ?

Loading firmware into Renesas H8/3048BF processor.

This is normally of no concern to user unless it is required to load new version of firmware for bug fixes and/or performance enhancements.

1. Run Renesas Flash Development Toolkit 3.1
2. Project
 Insert Project.....
 Project name e.g. PriorLF250
3. Select Device H8/3048BF
4. Select Port Use dropdown to select the correct port
5. Enter CPU frequency
 22.1184MHz
6. Leave radio button as BOOT MODE
7. Download file....
 Browse and select required .a20 file
8. Disconnect before exiting software.
9. Connect Hyperterminal using 115000,8,1,n
10. Power cycle LF250
11. Type VER<cr> to confirm the correct version of firmware has been loaded.

