

Table of Contents

1.	Important Safety Information	3
	Important Safety Information	3
2.	Product Description	5
	Product Description.	5
3.	Unpacking the System	7
	Unpacking the System	7
	Dovetail flanges.	7
4.	Installation	9
	Installation	9
	Mechanical Installation of H122 Focus Motor	10
	Installation of LF210	12
5.	Getting Started	16
	Getting Started	17
6.	RS232 Commands	23
	Commands specific to LF210 operating as Auto Focus unit.	25
	Commands specific to LF210 operating as motorised focus controller	37
7.	I/O connectors	39
	OUTPUT connector is High Density (3 Row) D type socket.	39
	TTL inputs.	41
8.	Principles of Operation	42
9.	Suggested settings for tuning	45
10.	Troubleshooting	57
	Troubleshooting	57
11.	System Specifications	58
	System Specifications	58
12.	Glossary of Terms	59
	Glossary of Terms	59
13.	Replacement Parts	61

	Replacement Parts	61
14.	Returns and Repairs	62
	Returns and Repairs	62
15.	Appendices	63
	How to Run HyperTerminal	64
	Loading Firmware	66

1. *Important Safety Information*

Important Safety Information

Do not expose the product to water or moisture.

Do not expose the product to extreme hot or cold temperatures.

Do not expose the product to open flames.

Do not allow objects to fall on or liquids to spill on the product.

Do not touch the glass plate fitted between the circular dovetail and the top plate. Any dust, dirt, fingerprints will cause degradation of image quality

Do not poke inside the open aperture in the base plate of the unit. There are delicate optical components which are easily damaged if touched.



WARNING. This unit emits visible laser light from the aperture in the base plate of the unit. The total continuous power does not exceed 1mW thus it falls into a CLASS 1 Laser Product. As such the user should not stare directly into the laser beam although the normal eye reflex response will offer protection. The laser power is less than most commercially available laser pointers sold in novelty shops.



DANGER. Under no circumstances unscrew the lid off the unit. The unit contains a CLASS 3B visible laser diode with a maximum continuous power of 35mW. This laser power is only accessible with the unit dismantled and should only be performed by Authorised Service Centres. Disassembly of the unit will void the warranty. This product does not contain consumer serviceable components.



Use only the proper type of power supply cord set (provided with the system) for this unit. Failure to do so could instantly destroy the electronics and laser diode. The unit requires +5VDC at 3 Amperes.



Always switch off the unit using the on/off rocker switch **SW1** or unplug the PSU (CON3) when plugging/unplugging the stepper motor (CON4) or DIGIPOT (CON2). It is safe to plug/unplug the RS232 connector (CON1) with the unit powered.

2. *Product Description*

Product Description.

The Prior Scientific Laser Auto Focus Module model LF210 is an advanced, integrated unit which combines a visible laser diode, associated optical components, detectors, and electronics with on-board micro controller. The controller can output analogue and digital signals suitable for controlling piezo or motor focus drives. The analogue output voltage is compatible with the Prior NanoScanZ piezo Z stage. When using the unit with the Prior Stepper motor, the Prior keypad (LF100K) with integral stepper motor drive unit is required.

It is a simple procedure to install the unit into the optical path of many of the popular laboratory microscopes using infinity corrected optics. Simply install the laser focus unit (LF210), then the Prior focus motor (H122) to the fine focus knob of the microscope and connect both to the LF100K.

The laser beam passes through the microscope objective on to the sample. The detection circuitry in the Module monitors the spot position on the sample and continuously servos the focus motor or piezo stage to keep the spot position static. Optimum visual focus is maintained.

The LF210 is best suited to metallurgical and semiconductor examination using incident illumination where the sample has a reasonably flat, reflective surface.

Using the LF100K keypad allows fully stand alone operation. The Micro Controller built into LF210 allows the unit to act as an intelligent motorised focus controller in addition to its primary task of automatic focus control. The closed loop action can be disabled, manual focus achieved using the integral rotary digipot and remote focus control can be implemented by connecting the RS232 communication port of the unit to a host p.c.

IMPORTANT INFORMATION:

There are two essential requirements required for correct operation of LF210:

Microscope must have infinity corrected optics (Infinity corrected objectives used in conjunction with tube lens.

It must be possible to insert LF210 in the collimated region of the microscope optics. This is the region between the objectives and the tube lens.

The LF210 system will not function correctly using DIC optics.

3. Unpacking the System

Unpacking the System

Each Laser Focus system should consist of the following:-

Component	Component Description
A	Model LF210 Laser Focus Module
B	Appropriate set (top/bottom) of dovetail flanges for a particular Make/Model of microscope. (see below)
C	Model LF100K Control Pad/stepper drive. This is mandatory if stepper motor focus drive is being implemented but optional when used with piezo drive since the LF210 can be controlled entirely from a p.c. (RS232 communication)
D	Model H407 desktop PSU +24V at 60VA . This is plugs into LF100K and provides power for the H122 stepper motor.
E	Model H122 Focus Drive with correct clamping ring (see below)
F	Model W3299 desktop PSU +5VDC at 20VA. to power LF210

Dovetail flanges.

These come as a pair and will be factory fitted to the top/bottom halves of the LF210 unit to fit the correct microscope manufacturer/model number. The part numbers are as follows:-

Flange Part Number	To fit microscope
LF310	Leica
LF320	Nikon
LF330	Olympus BH
LF335	Olympus BX
LF340	Zeiss
LF350	Mitutoyo

Flanges for other microscopes are available. Please contact Prior Scientific Instruments for details.

Note: Make sure that all of the components that should be included with your LF210 System have been supplied. If parts are missing please contact your local Prior Dealer.

Take great care when unpacking the LF210 Unit In particular do not touch the glass plate in the lid of the unit or poke any object up the aperture in the base. This could cause significant loss of performance or failure of the unit.

4. Installation

Installation

Identification of Parts:

LF210, Laser focus head.

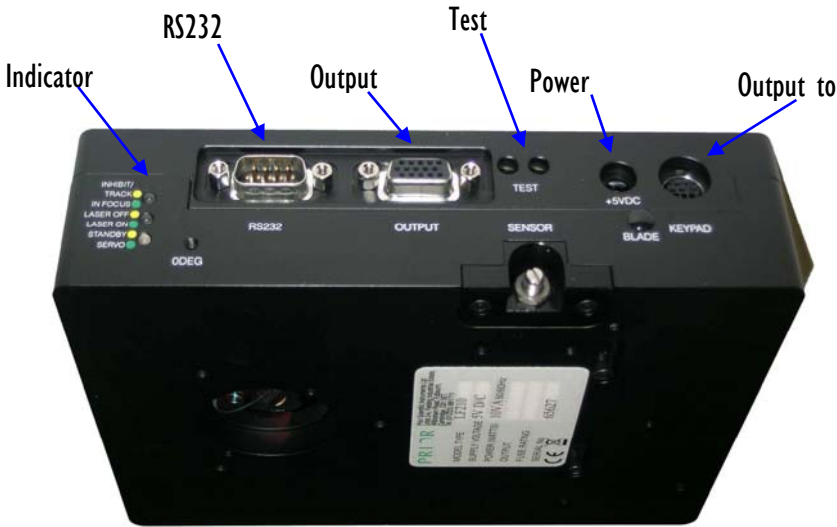

LF100K, Keypad and digipot control.

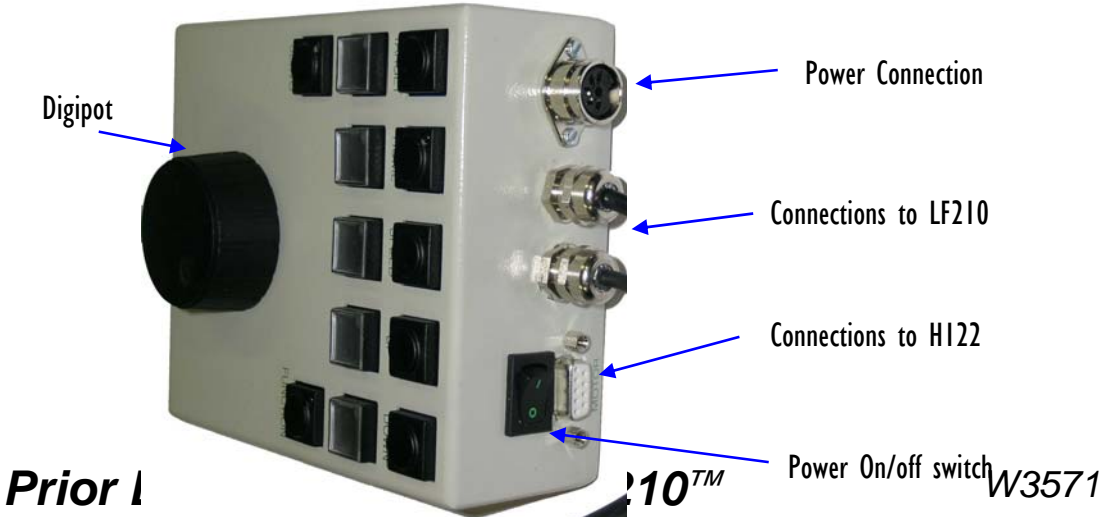

Mechanical Installation of H122 Focus Motor

- Loosen the clamp screw on the focus motor assembly and remove the focus motor from the focus adapter (fig.1)
- Loosen the 3 socket set screws around the periphery of the focus adapter using a 2mm Allen wrench until the focus sleeve is able to fit inside the adapter. Note that it is important to insert the sleeve in the correct orientation with the lip furthest inside the adapter (the chamfered edge of the sleeve will be inserted first). Note the orientation of the sleeve as it has a recess around its outer surface, which will hold the sleeve in when the set screws are tightened. This recess must line up with the tips of the socket set screws. (See fig.1).
- With the sleeve in place, tighten the 3 socket set screws in sequence until they all just touch the sleeve, ensuring that the split in the sleeve does not line up with any of the set screw positions. **DO NOT TIGHTEN UP ANY OF THE SET SCREWS AT THIS STAGE.**

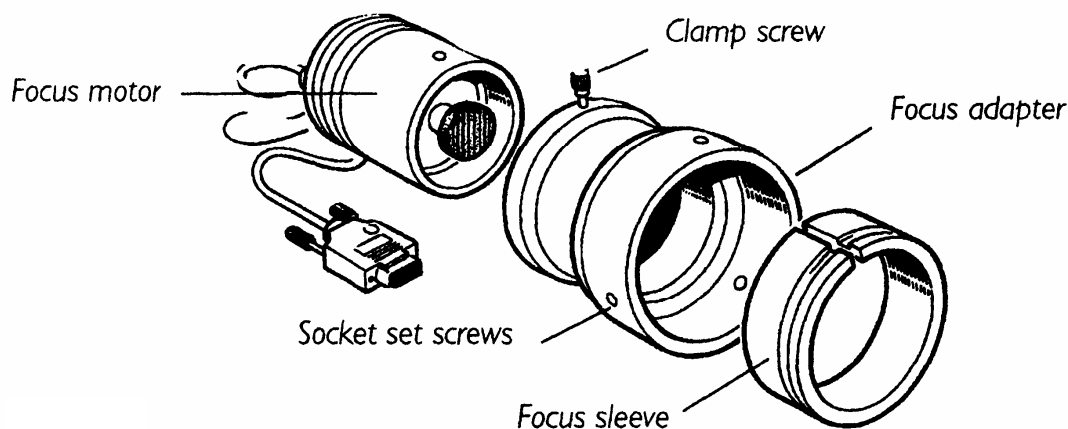

- Figure 1: Focus motor and adaptor setup.
- Push the adapter onto the preferred coarse knob of the microscope as far as it will go. The preferred side is normally the left side of the microscope (as viewed by the operator) since H122 will then not interfere with the drop down controls of the stage which are often down the right side of the microscope. The inside fitting diameter of the

sleeve is designed to be slightly larger than the coarse knob, provided the set screws have not been tightened and are compressing the sleeve.

- While holding the adapter in place, tighten the set screws in sequence only enough to secure the unit onto the coarse focus knob. The focus knob will have to be rotated to gain access to all of the screws.
- Check that the unit has been tightened sufficiently by taking hold of it and turning it. If the adapter is correctly fitted it will stay attached to the coarse knob.
- Slide the focus motor into the adapter as far as it will go and while applying gentle pressure to the motor tighten the clamp screw. This will hold the motor in place. The rubber drive bush on the end of the motor spindle should now be pressing against the end surface of the fine focus control knob. This can be confirmed by manually rotating the exposed fine focus knob on the opposite side of the microscope and feeling for the resistance caused by the detent positions of the stepper motor as it rotates. This will not cause any damage to the focus motor.
- The standard friction drive is adequate for normal use of a focus motor, for the LF210 it is recommended to use a direct connection drive.

Installation of LF210

- Microscopes with detachable incident illuminator:
- Remove the binocular/illuminator from the nosepiece using the Allan key provided by the microscope manufacturer and place it to one side.
- Fit the Laser Focus to the microscope using the same Allan key.
- Orient the LF210 so that the front of the unit faces the front of the microscope.
- Screw in the Prior alignment objective insert into a spare location of the microscope nosepiece.
- If none are free then remove one objective and fit the alignment objective insert.
- Check that the on/off rocker switch at back of LF210 is off
- Connect W3299 to mains socket
- Connect W3299 power supply unit (PSU).
- Connect your computer (running Windows 98/2000/XP): Plug the RS232 cable into RS232 socket on the computer and LF210.
- Prior Scientific offers this cable as an optional accessory (H276).
- Switch on LF210 using rocker switch on at back of unit.
- The STANDBY/SERVO led will illuminate yellow.
- Should the LED not illuminate, check the power supply connections.
- Slide out cylindrical lens out of the laser beam to follow this procedure and then slide it back afterwards.
- In most cases the factory alignment is of sufficient quality that the unit can be fitted without adjusting the 45^o dichroic.
- A semicircular red laser beam should be seen falling onto the alignment objective insert as shown in *figure 1*.

This can conveniently be seen by placing a mirror or other flat reflective surface on the stage so that the observer can see the reflection of the alignment objective insert and laser beam in the mirror. If using this technique **WEAR APPROPRIATE EYE PROTECTION.**

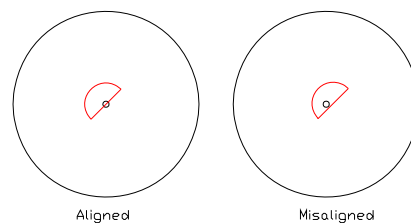

Figure 1: Alignment diagrams.

- The aim is to adjust the position of the semicircle so that the middle of straight edge of the semicircle coincides with the 1mm hole in the alignment objective insert (this is the optical axis of the objective lens). If the alignment is not correct then steer the laser beam to the correct position by inserting the 1.5mm long reach Allan key supplied into the apertures marked 0DEG and 45DEG. See figure 2 below. Care should be taken to insert the Allan key vertically down through the aperture since it has to locate into the head of a grub screw. Small adjustments of one or both settings will move the laser beam to the correct position.
- Remove alignment objective insert and, if necessary put back objective lens.
- Slide back into position the cylindrical lens.
- Fit illuminator/binocular unit to top flange of LF210 using the same 1.5mm Allan key.
- Ensure that the dovetail fittings are secure.
- If the dovetail fittings do not fit then check the part numbers for the dovetail fittings (Section 3).

Microscopes with incident illuminator integral with the nosepiece (i.e. they cannot be separated.):

- Remove the binocular head and insert LF210 between binocular head and illuminator/nosepiece using the same procedure as described above.

It is preferable to place the LF210 unit between the illuminator and the nosepiece, the laser light does not pass through the illuminator beam splitter in this configuration.

- Ensure LF210 is in correct Configuration Mode for your external drive equipment, (see Section 5, configuration modes).
- Switch off LF210.
- Ensure switch on LF100K is off.
- Connect LF100K to LF210 using the 2 leads attached to LF100K.
- The 8 way Mini-Din plugs into the socket marked KEYPAD.
- The 15 way D type plug fits the Socket marked OUTPUT.
- Connect +24V desktop PSU to 3 pin socket at back of LF100K.
- Connect Power Supply Unit (PSU) to mains using mains lead supplied.
- Switch on LF100K.
- Switch LF210 on.
- Select x50 objective and achieve a best focus on a typical sample surface in the usual manner. (Use coarse focus knob for large adjustments).
- The H122 focus motor should be attached, provided it is supplied no power (rocker switch at back of LF100K is off) it is safe to operated the fine focus knob manually.
- Run Windows HyperTerminal Application (see Appendix C).
- Successful communication between LF210 and computer has been achieved when pressing the Enter key “<cr>” returns 3 numbers (12345,12345,12345).
- Type “TEST.1”
- The LF210 will continuously output 3 numbers every 1/10second.

- The first number is (A-B), (A-B) is the Difference and will be within the range -3000 to +3000.
- The second number is “Calculated spot position”.
- The third number is (A+B), (A+B) should be approximately 2000. This is a representation of the intensity of laser light being reflected off the sample and falling on the sensor.
- Use a flat bladed screwdriver to adjust the height of the sensor (marked SENSOR) to adjust (A-B) to within -50 to +50.

Note: If (A-B) is saturated at +3000: turn the sensor anticlockwise (counter-clockwise). If (A-B) is saturated at -3000: turn the sensor clockwise.

- Switch on the LF100K.
- Use the digipot to move the focus either side of best focus
- Observe (A-B) changing positive and negative.
- The unit is now mechanically set up correctly.

5. *Getting Started*

Getting Started (LF210 with LF100K and H122 stepper motor)

Using the KeyPad (LF100K)

The LF100K allows standalone operation of the system and also incorporates stepper motor drive circuitry to allow the LF210 to drive Prior H122 stepper motor.

The basic functions it offers are as follows:-

- Rotary digipot offers remote motorised operation of the fine focus of the microscope. (Only available when SERVO key is not active.)
- Allows optimum servo response for any magnification objective using Objective Select Keys 1 to 9.

After correctly complete the setup procedure:

- Write the objective magnification on the buttons marked 1-5.
- The buttons have clear plastic snap in tops with white inserts.
- Remove the white insert and write on the magnification before replacing the white insert.
- It is suggested that the lowest magnification is the lowest number button e.g., x5 x10, x20, x50, x100 are buttons 1,2,3,4 and 5 respectively.
- Start by rotating the nosepiece until the x20 objective is in place. Press the key corresponding to this magnification. This now will associate all subsequent settings to this objective.
- Put the microscope in focus - Use the digipot to fine adjustment of focus.
- Press TARGET button. This establishes this as the target best focus the module will servo to.
- *Note: This TARGET position is not a target Z position as this will change with stage movement and for a sample with differing height or with tilt.*
- The initial set up for objective 3 is now complete.

- Advanced configuration (electrical servo gain “KP” and damping “KD”) are completed by connecting via HyperTerminal (see Appendix C)
- Use the rotary digipot to move the focus slightly away from best focus.

Warning: Be prepared to turn SERVO off by pressing the SERVO button again.

- Press the SERVO key.
- The STANDBY/SERVO led on the side of LF210 will change from yellow to green.
- The focus motor will rotate a small amount to bring the image back to best focus and then stop.
- If the motor continues to turn and does not stop at best focus. Turn SERVO off by pressing the SERVO button a second time.

Warning: It is possible for the focus motor to drive continuously or oscillate.

- If the focus motor turns continuously, reverse the sign of KP, (See section below)
- If the focus motor oscillates, reduce the magnitude of KP, (See section below).

Setting KP values:

- This has to be done by sending RS232 command from the Computer via HyperTerminal. The value of KP needs to be adjusted so that the response is quick but not liable to oscillate. Start with small value of KP and increase in increments. Remember to use SAVE command to store the optimum value of KP to non-volatile memory otherwise the new value will be lost on power down.
- Connect to the LF210 using HyperTerminal
- Send the command “KP,##” where ## is between 20 and 2000.
- Send “SAVE” when finished and happy with the settings.

The table below describes the function of each key.

Note that FUNCTION+KEY works as follows:-

Press FUNCTION key. LED will flash indicating its active.

Release FUNCTION key then press appropriate key.

This completes the action. Note that the FUNCTION key then becomes inactive (indicated by its led going out)

The exception to this operation of FUNCTION/UP and FUNCTION/DOWN which increases/decreases buzzer volume respectively. Here FUNCTION key is kept pressed whilst repetitively pressing UP/DOWN key FUNCTION key is cancelled afterwards by pressing it again.

Description of Key usage.

Key	Operation
1 to 5	<p>Selects the optimum parameters for the particular objective.</p> <p>The following parameters are associated with each objective and are normally pre set using the RS232 communication with computer and/or using keystrokes with the FUNCTION key (see below).</p> <p>The pre set parameters for each objective are TARGET,KP,KD(see RS232 Commands)</p>
SERVO	<p>Switches on and off the SERVO or Auto Focus function.</p> <p>STANDY/SERVO goes green when SERVO is active.</p> <p>Switching SERVO off enables the Digipot. The LF210 will also then function as an intelligent motorised focus drive controlled using commands sent along the RS232 connection (if fitted to a computer)</p> <p>SERVO/STANDBY mode of LF210 is also indicated by the LEDs on the front of LF200</p>
UP	<p>With unit in STANDBY holding UP button will cause focus to move up continuously at a speed set by the SPEED button.</p>

Key	Operation
DOWN	With unit in STANDBY holding DOWN button will cause focus to move down continuously at a speed set by the SPEED button.
SPEED	With unit in STANDBY each successive momentary depression of this button will cycle the speed at which the focus moves using UP/DOWN buttons or Digipot through 100%/25%/50% The preferred setting is stored even through a power cycle. This button will change the speed setting whether motor is moving or stationary. The unit must however be in STANDBY .
HOME	Moves stage to a preset HOME position.
TARGET	Use the digipot establish best visual focus. Pressing this key will set this as the focus which will be maintained during SERVO action for the current objective.
FUNCTION/UP	Keeping FUNCTION key pressed whilst repetitively pressing UP key increases volume of buzzer. Note that a maximum volume will be reached such that further presses of the UP key has no effect.
FUNCTION/SPEED	Switch Laser on/off
FUNCTION/DOWN	Keeping FUNCTION key pressed whilst repetitively pressing DOWN key increases volume of buzzer. Note that minimum volume is the buzzer switched off.
1 to 9	Selects the optimum parameters for the particular objective. The following parameters are associated with each objective and are normally pre set using the RS232 communication with p.c. and/or using keystrokes with the MODE key (see below). The pre set parameters for each objective are TARGET,KP,KD,MIN,DEAD (see RS232 Commands)

Key	Operation
SERVO	<p>Switches on and off the SERVO or Auto Focus function. LED is lit when SERVO is active.</p> <p>Switching SERVO off enables the Digipot. The LF400 will also then function as an intelligent motorised focus drive controlled using commands sent along the RS232 connection (if fitted to a p.c.)</p> <p>SERVO/DIGIPOT mode of LF200 is also indicated by the LEDs on the front of LF200</p>
UP	<p>With unit in DIGIPOT mode holding UP button will cause focus to move up continuously at a speed set by the SPEED button.</p>
DOWN	<p>With unit in DIGIPOT mode holding DOWN button will cause focus to move down continuously at a speed set by the SPEED button.</p>
SPEED	<p>With unit in DIGIPOT MODE each successive momentary depression of this button will cycle the speed at which the focus moves using UP/DOWN buttons or Digipot through 100%/25%/50%</p> <p>The preferred setting is stored even through a power cycle. This button will change the speed setting whether motor is moving (using UP/DOWN/DIGIPOT) or stationary. The unit must however be in DIGIPOT MODE.</p>
HOME	<p>Moves stage to a preset HOME position.</p>
TARGET	<p>Use the digipot establish best visual focus. Pressing this key will set this as the focus which will be maintained during SERVO action for the current objective.</p>
MODE + HOME	<p>This establishes the current position to be the HOME position. Future use of HOME key on its own will move the focus to this position.</p>

Key	Operation
MODE+SPEED	Sets the current position to Absolute Zero. This will often be the parfocal distance of the set of objectives. In most instances this position is not useful except when using unit as an intelligent motorised focus drive.
MODE/UP	Keeping MODE key pressed whilst repetitively pressing UP key increases volume of buzzer. Note that a maximum volume will be reached such that further presses of the UP key has no effect.
MODE/SPEED	Switch Laser on/off. Laser will always be on power up.
MODE/DOWN	Keeping MODE key pressed whilst repetitively pressing DOWN key increases volume of buzzer. Note that minimum volume is the buzzer switched off.

6. RS232 Commands

LF210 Module can accept commands from a host computer (running Application Software or Terminal Emulation Program) using the RS232 serial port. The port defaults to a baud rate of 115kB (settings 115200,n,8,1)

All commands are terminated with a Carriage Return code <cr>

Commands are separated from arguments by one or more of the following delimiters.

COMMA

SPACE

TAB

EQUALS

SEMICOLON

COLON

Thus to move the focus UP by 100 steps the user could enter any of the following

U,100<cr>

U 100<cr>

U:100<cr>

U;100<cr>

U100<cr>

Proof of successful acceptance of any command sent to LF210 is the response '0'<cr> The response is immediate i.e. it does not wait for the command to be completed.

Commands can be stacked (queued) although they are not necessarily acted upon immediately. e.g. sending a move command U,1000 immediately followed by PZ,0 will zero the Z position after the Up move has finished.

If a command is not valid a response of “E,n” is returned. The n specifies an error type as listed below. The error codes are the same as for Prior Scientific’s other motor controllers (ProScan and OptiScan)

ERROR CODE	ERROR DESCRIPTION
2	NOT IDLE
3	
4	STRING PARSE
5	COMMAND NOT FOUND
7	
8	VALUE OUT OF RANGE
10	ARG1 OUT OF RANGE
11	ARG2 OUT OF RANGE
12	ARG3 OUT OF RANGE
13	ARG4 OUT OF RANGE
14	ARG5 OUT OF RANGE
15	ARG6 OUT OF RANGE

Commands specific to LF210 operating as Auto Focus unit.

Command	Argument (range)	Response	Description
CONFIG	None	K,S,N	Reports configuration mode where: K = default gain settings for OEM piezo without internal PID loop N = gain settings for Prior NanoScanZ stage with closed loop integral height sensor S - gain setting for Prior stepper motor control.
CONFIG	n(K,N,S)	0	Sets 50X objective default values for Gain Settings: KP,DK,KI,Delay,DelayD,Rate where: K = default settings for OEM piezo without internal PID loop N = setting for Prior NanoScanZ stage with closed loop integral height sensor S - gain setting for Prior stepper motor control.
KP	none	p	Reports the proportional gain setting
KP	P-gain(-2000 to 2000)	0	Sets the Proportional gain. The proportional gain regulates the speed the system responds to a focus error. The proportional gain is the error signal multiplied by a gain constant which controls the drive. Decrease this value for better stability but slower response. Typical value are between 20-200. If the unit makes the focus drive continuously away from Target then it is likely that the loop is negative, not positive feedback and so negative values should be used.
KD	none	d	Reports the differential gain setting.

KD	D-gain (-10000 to +10000)	0	The differential gain parameter reduces any oscillations the system caused by the external drive overshooting the optimum position. A differential controller is used to stabilize the output signal, it predicts the future state of the system using the current rate of change of measure values. By analysing the rate of change it is possible to calculate how much the drive system will go past the optimum position and change the rate of change to compensate for this. The differential value is multiplied by the KD constant value. Increasing this value from zero will reduce the overshoot as the focus approaches best focus. If the opposite happens then enter negative values. It is found that using LF210 to control H122 stepper motor or Prior NanoScanZ piezo stage the default value of zero is optimal.
KI	none	I	Reports the integral gain setting.
KI	I-gain(-1000 to +1000)	0	Sets the Integral Gain Value (I). Integral gain is the sum of all previous error signals multiplied by a gain constant and fed out to the drive. The integral term becomes very large and so it is multiplied by small numbers for use in the LF210. This command is used to set and read the gain constant, which gets divided by 65000 for use in the system. In most instances KI is ignored and set to zero. The default value is zero.
Rate	none	r	Reports slew rate (r) of the digital to analog converter

Rate	bits (1 to 100)	0	The Slew rate is a second parameter which can be used to reduce any oscillations the system caused by the external drive overshooting the optimum position. The Slew rate of the Digital to Analogue Converter (DAC) that is used for output to the NanoScanZ can be controlled. The rate of change of the output can be controlled via this parameter, a value of 1 means that each subsequent DAC output can only change from the previous value by a maximum of 1. The DAC outputs a value every 1msec.
Delay	none	D	Reports the Servo Delay Setting (D).
Delay	D(TBD)		Sets the Servo Delay Setting (D) The servo loop is run every 1ms. This command will reduce the run rate of the loop if required. The default value is zero. This command will only need to be used if the piezo focus drive being used to move the focus position is slow to respond. The standard loop time is 1ms. Each unit of delay increases the loop time by 0.1ms. In most cases this should be set to zero.
DelayD	none	D	Reports the Dynamic Delay Setting (D)
DelayD	D(TBD)	0	Sets the Dynamic Delay (D). This is an additional delay setting. Dynamic Delay is utilized in lieu of (Delay) when the (Delta) error is greater than 40,000 or less than -40000. In most cases this should be set to zero. Default is zero.
Target	none	0	Sets the Target position for a particular objective.
Target	?	t	Reports the value for the target position stored during the (Target) command.

Target	pos	0	Sets the laser target position to a known value. Should a sample have 2 or more known heights the target value can be changed for each height. Where surfaces at different heights have significantly different reflectivities, the (ADC) command can be used to determine when to switch between target positions.
--------	-----	---	---

Target	B	0	<p>There are some extreme situations where the surface characteristics vary wildly, so much so that the laser spot/line shape is different on each surface even though the surfaces are at the same height and therefore stay in best visual focus. One such example is chrome on glass. If the glass substrate is thin then the laser reflection off bottom surface upsets the laser light distribution. The reflectance of the top surface is also dramatically different. Move one type of sample surface under the laser beam, achieve best visual focus and type TARGET,W (white), move to other type of surface (refocusing if necessary) and type TARGET,B (black), type MODE,1 and best visual focus is maintained on either surface. Use TEST,4 to confirm correct operation. The LF210 uses the Reflectance to calculate a Target Spot Position. It assumes a linear behaviour for any surface which has Reflectance different from the 2 used to do this calibration. It is advisable to mechanically adjust the sensor so that (A-B) for the 2 surfaces at best focus lie approximately either side of zero e.g, it is better to have A-B +/-700 and not 0 and 1400</p> <p>IMPORTANT</p> <p>TARGET,W TARGET,B calculates a REFLECT number which is proportional to slope of Target Spot Position vs Reflectivity. Reverting to a single target set using TARGET,s will cancel this feature and RELECT will be set back to zero. Alternatively typing REFLECT,0 will cancel. LIST will confirm that this feature is cancelled by returning REFLECT,0 in the list.</p>
Target	W	0	See above.

INHREF	none	min,max	Reports the minimum and maximum reflectivity setting between which the LF210 will continue to servo i.e... Mode 1.
INHREF	min(0-49000),max(1-50000)	0	Allows the LF210 to toggle between Mode 1 and Mode 2 when scanning across surfaces such as chrome and glass where glass would cause an undesirable focus shift. Any reflectivity less than the minimum or greater than the maximum will switch the LF210 into Mode 2(standby), moving back into the reflectivity range automatically returns the unit to servo mode 1.Any Reflectivity number >50000 is considered as a fault condition and will put the unit into MODE,2 (standby) Use ADC or TEST,4 to observe the reflectance of the surfaces Default max is 50000, Default min is 0 Second parameter (max) is optional INHREF,0 will set min to 0 and max to 50000 INHREF,500 will set min to 500 and max stays at 50000 INHREF,500,2000 sets min to 500 and max to 2000.
Delta	none	error	Reports the error between the target laser spot position and the measured laser spot position. (TARGET) will set this to zero.
Laser	none	intensity	Reports the current laser intensity.
Laser	I(1-4095)	0	Sets the laser intensity. Less reflective samples require higher laser intensity for optimal performance Default value is 2000.
Laser	D	0	Disables the laser. Command can be used to capture an image without the laser visible.
Laser	E	0	Enables the laser. Note simply changing the laser intensity does not turn the laser back on.
Obj	none	O	Reports the objective currently selected.
OBJ	O(1-6)	0	Selects the current objective and all settings associated with it.

OBJ	O(1-6),M(4-200)	0	Sets objective magnification and associated KP value equal to 25000 divided by M OBJ,1,50 sets KP to 50.
Piezo	none	piezo position	Reports piezo control voltage in DAC counts (0-4095) as specified by (OUTPUT).

Piezo	n(+4095 to -4095)	<p>This command should only be used in Mode 2</p> <p>Changes the analog voltage on pin 3 of the 15 way socket to control piezo position. From the midway voltage defined by the (OUTPUT) command Piezo,2047 increases the output to maximum voltage and Piezo,-2047 will bring you to the minimum voltage when starting from the middle of the voltage range.</p> <p>Example:</p> <p>Output ,0,4000 sets piezo range from 0-4V with starting voltage at the midpoint = 2V</p> <p>Piezo Returns 0 = 2V starting point</p> <p>Piezo,2047 Sets piezo voltage to maximum of 4V</p> <p>Piezo Returns 2047</p> <p>Piezo,-4095 Sets piezo voltage to minimum of 0V</p> <p>Piezo Returns -2047</p> <p>Piezo,2047 Sets piezo voltage to midpoint = 2V</p> <p>Piezo Returns 0</p> <p>It is important to note the following:-</p> <p>Do not connect PIEZO voltage output to the device which is to be driven until it is established that the voltage range is limited to the voltage range for the device. Failure to do this could damage the piezo drive circuitry. Output voltage is generated from a 12 bit DAC therefore full voltage range is 4095 steps. Thus for OUTPUT,0,10000 gives 2.44mV per step. Reading PIEZO returns an absolute position (+/- 2047). PIEZO,n is a relative step move. In MODE,2 only PIEZO,n command or moving digipot will change PIEZO voltage.</p> <p>Absolute range is +/-2047. Any attempt to go outside this range using PIEZO,n will be truncated .</p> <p>to keep absolute position to within +/- 2047</p>
-------	-------------------	---

Infocus	none	0 or 1	Reports whether the sample is in focus. 0 = out of focus, 1 = in focus Sample is in focus when (Delta) is within +/- (FOCUS) value, see (FOCUS) Command Note: When Infocus = 1, InFocus LED will go green and InFocus TTL will go low When Infocus = 0 LED will flash yellow.
Focus	none	n	Reports the range (n) that the sample can drift from the target position before triggering a servo move LF210 will servo until (Delta)<0.5n. Servo will re-activate once (Delta)>+/-n.
Inhibit	none	N	Returns Inhibit status. 0 = normal operation, 1 = in inhibit mode.
Inhibit	N(minimum = 1)	0	N is the value of (A+B) visible light on the sensor below which the calculated error will be forced to zero. In mode 1 this would freeze the output voltage, or stop output pulses to the stepper In mode 0 voltage would fall to zero. The InFocus LED will switch to Red and the Infocus TTL will go low when (A+B) falls below this value. Default value is 250.
Mode	none	0-2	Reports the Operating Mode
Mode	0-2	0	Sets the Operating Mode of the LF210 Mode,1 = Servo Mode Mode,2 = Stand by/Open Loop Mode Mode,0 = Height Sensor Mode - open loop - not recommended.

Output	none	Vmin,Vmax	Reports the minimum and maximum output mV for piezo control (pin 3 of 15 way socket) - Mode 1 and 2 Reports the minimum and maximum output mV for error signal (pin 3 of 15 way socket) - Mode 0 e.g. Output,-4000,4000 sets voltage to +/- 4V Output ,0,10000 sets output voltage to 0-10V Note that this range cannot be set unipolar and negative, for example Output,-4000,0 is not valid.
Output	Vmin,Vmax	0	Sets the minimum and maximum output voltage for piezo control, Mode 1 and 2 Sets the minimum and maximum output voltage for error signal, Mode 0.
Pos	none	pos	Reports the spot position on the sensor. The spot position is calculated as $65535*(A-B)/(A+B)$.
Save	none	0	Saves parameters from volatile memory into non-volatile memory. Any changes between saves will be lost with a power cycle.
Load	none	0	Loads the parameters saved in non-volatile memory back into working memory.

List	none	see description	Lists all user settable values associated with the current objective. List ends with END which should be used to identify end of LIST (so additional lines can be added) Note that this command should be preceded by the correct objective required using OBJ,n e.g. VERSION 027 OBJ 4 KP 100 KD 500 KI 0 RATE,1 DELAY 200 DELAYD 0 LAG,1 LASER 2000 INHIBIT 250 FOCUS 5000 OFFSET 0 0 MODE 2 REFLECT 0 END
Version	none	software version	Returns 3 digit software version number.
Date	none		Returns date of software compilation and build number.
ADC	none	(a-b), reflectance ,(a+b)	Useful when setting INHREF command.

S	none	pos,(a+b), delta	<p>This command may be useful to the user for diagnostic purposes</p> <p>For instance the user can carry out the following sequence:-</p> <p>MODE,2 (allows manual movement to best visual focus)</p> <p>TARGET (sets current spot position to Target)</p> <p>PIEZO,-1000 (moves stage down by 1000 steps)</p> <p>S (outputs (a-b), spot position, (a+b))</p> <p>PIEZO,1 (moves stage up by 1 count)</p> <p>S (outputs (a-b), spot position, (a+b))</p> <p>loop 2 steps above.</p> <p>User has (A+B) and DELTA which can be plotted against height(PIEZO)</p> <p>A note of warning.</p> <p>The user should be aware that PIEZO,n changes the voltage input to the piezo stage.</p> <p>Prior NanoScanZ piezo stage has its own integral height sensor and operates in closed loop mode such that input voltage (0-10V) and mechanical position are accurately related. If the LF210 is inputted to a piezo stage which has no internal feedback the relationship of voltage input to mechanical position will be inaccurate and show substantial hysteresis therefore PIEZO voltage will not represent the accurate mechanical position.</p>
Keypad	"0" or "1"	0	<p>Zero will disable the LF100K keypad, one will enable the keypad. Use the "save" command to save this setting.</p>
TTL	"0" or "1"	0	<p>One will enable TTL outputs, zero will disable TTL outputs. Outputs are disabled automatically upon every start-up</p> <p>See section 7 for definition of TTL inputs.</p>

Reset	none	0	Resets to factory defaults. Note that all variables saved to non-volatile memory will be lost.
Test,1	t	see description	Test,1 will display (a-b), spot position, (a+b) every 100 ms. The argument t can be omitted for 100 ms intervals or changed for more or less frequent intervals. Useful for diagnostic purposes.

Commands specific to LF210 operating as motorised focus controller

Note SERVO must be disabled (i.e. be in MODE0 or MODE1) for LF210 to operate as an intelligent motor controller responding to commands sent along the RS232 port.

Command	Argument (range)	Response	Description
Z			Sets absolute motor position to 0
GZ			Moves motor to Absolute Position n.
PZ			Returns motor position
C	n		Sets the step size when using U and D commands.
U	n		Moves the motor position Up by n counts. Convention is that Up will increase motor position. If n is omitted the step size is defined by C command.
D	n		Moves the motor position Down by n counts. Convention is that Down will decrease motor position. If n is omitted the step size is defined by C command.
ZD	n		Reverses the direction of the motor when instructed to go to position P from zero position.

			n=+1 or -1 Default ZD=1
SMZ	n		Sets the maximum rotational velocity of motor to n. Units are % Range 0-100% Default 50%

7. I/O connectors

OUTPUT connector is High Density (3 Row) D type socket.

.Pin number	Signal Type	Input/Output	Range/comments
1	GND		
2	Sum	output voltage	0-10V
3	Piezo pos/error	output voltage	Defaults to 0V-4VDC (OUTPUT,0,4000) but can be changed using OUTPUT command. In MODE,2 the output voltage is midway between Vmin and Vmax at power-up and can be altered using the PIEZO,n command.
4	Position	output voltage	Proportional to Calculated spot position. Range is +/-5V
5	GND		
6	Pulse	TTL Output	Outputs pulses at a rate proportional to ERROR. Used to control stepper motor drive in LF100K
7	n/c		
8	n/c		
9	n/c		
10	Dir	TTL output	Used with Pulse to determine direction of drive for stepper motor.
11	n/c		
12	n/c		
13	+5V output		
14	In Focus(L)	TTL Output	InFocus flag (see INFOCUS command)

15	Inhib(L)	TTL Output	Inhibit flag (See INHIB command)
----	----------	------------	-------------------------------------

Notes

2) Intensity. This is (A+B) and is a purely analogue signal (A and B are rectified and added) i.e. it does not go through any ADC/DAC conversion

3) Mode 1/Mode2 this is piezo output voltage .Mode 0 converts voltage to Error Voltage proportional to Spot position error). Output voltage range set using Output command.

6) Pulse output. MODE,1/MODE,2 should be used for this. e.g., if OUTPUT,0,4000 then piezo voltage sits at 2.000V. However setting TARGET and then MODE,1 will output up/down pulses to maintain spot position at Target position.

Note that the pulse rate will be affected by the KP,KD,KI values in the same way as the analogue output voltage on pin 3

TTL inputs.

Unit has 4 TTL inputs using the 8 way Min-Din socket. The contact assignment is as follows:-

Any user wishing to use these TTL inputs can obtain a suitable cable from Prior Scientific (Prior part number W1867)

These inputs are inactive by default.

Use command TTL,1 to activate these inputs

Use SAVE to ensure that they are active for all subsequent power ups

These inputs allow control of LF210 without needing to use the RS232. The response to these inputs will be faster than sending the same commands via RS232.

Contact	Cable wire colour	TTL numbering.	
1	black	TTL2	
2	white	+5Vout	
3	red	TTL4	MODE 1(H)/MODE 2(L)
4	yellow	A(encoder 0Deg)	
5	purple	TTL1	
6	blue	0V	
7	green	TTL3	LaserOn(H)/Off (L)
8	brown	B(encoder 90Deg)	

TTL1 and TTL2 select the objective as below.

TTL1	TTL2	OBJ
0	0	1
0	1	2
1	0	3
1	1	4

8. Principles of Operation

The LF210 relies on the knife edge principle.

Half the aperture of the collimated light is blocked. The diagram below shows how this spoils the symmetry of the optical system about the optical axis. The collimation of the laser beam is adjusted to be the same as the objective lenses so that the best visual focus and the laser focus coincide. Moving the focus either side of focus not only defocuses the laser spot but moves laterally on the sample surface.

The reflected light retraces the path of the incident beam, 50% reflecting off a beam splitter through a focussing lens onto a duo lateral silicon position sensor. The image falling on the position sensor is effectively the same as seen by the camera viewing the sample.

The position sensor has 2 electrodes. The spot generates current from each electrode A and B. If the spot is in the centre $A=B$. The sum $(A+B)$ is proportional to light intensity. If the spot moves to the right B increases and A decreases (say).

$$\text{Spot position} = K(A-B)/(A+B)$$

$$\text{Light intensity} = C(A+B)$$

Where K and C are proportionality constants.

$(A + B)$ is created using summing amplifier to give voltage proportional to intensity.

$(A - B)$ are created using difference amplifier.

SUM(A+B) and DIFFERENCE(A-B) voltages above are simultaneously read by high precision 16 bit DAC every 1msec.

$$\text{Range of Sum} = 0V-10V = 0-32768$$

$$\text{Range of Difference} = +/-10V = +/-32768$$

$$\text{Calculated Position} = (\text{DIFFERENCE} * 65536) / \text{SUM}$$

Target Position can be set by reading Current Calculated Position.

$$\text{Calculated Error} = \text{Calculated Position} - \text{Target Position.}$$

Analogue Error Voltage = (Calculated Error * Gain)/10000

If Analogue Error Voltage exceeds +/-2047 then value is set to +/-2047.

Background light/current leakage which would result in voltage offsets are measured on power up prior to the laser being switched on. As a result it is important to ensure that all covers of unit are in place before power up.

Microprocessor calculated spot position using the formulae above.

LF210 has 3 test routines which may be useful during installation and fault diagnostics.. These tests are enabled using a Terminal Emulation program such as Windows HyperTerminal and enables the user to constantly read the values during installation. The TEST can be stopped by typing TEST,0 or a power cycle..

Note that an optional second parameter can be used to determine time interval between print outs (time units are milliseconds)

TEST	0		stops all test reports.
TEST	1,delay		Difference (-4095-+4095),Calculated Position (+/-200000) and Sum (0-4095) every 1/10 second. Difference = A-B Sum = A+B Position =65535*(A-B)/(A+B) Delay is optional and specifies the delay time in milliseconds between displays. Default is 100.
TEST	3		Calculated Error (DELTA). This is Calculated Position – Target Position. With no Target Position entered or TARGET,0 entered then Calculated Error = Calculated Position.
TEST	4		Difference,Calculated Position,Sum,Laser Intensity(LI),Reflectance LI is number proportional to output of sensor integral with laser diode. Reflectance is proportional to (A+B)/LI

9. *Suggested settings for tuning*

The user should first configure LF210 for the type of drive connected to the 15 way output socket using the CONFIG command. This sets parameters which should be most suited to x50 objective and should work for lower power objectives but at low response speed. The parameters are initiated to be the same for all Objectives (see OBJ command)

One technique to improve servo response is as follows:-

In MODE,2 (open loop) run TEST,1 with image at best focus. Confirm (A-B)= ± 500 . Use mechanical adjustment of sensor to achieve this. Type TEST,0 to stop test.

Type TARGET<cr>

Type MODE,1

If unit runs off then type MODE,2.. It is likely that KP needs to be reverse sign (positive feedback)

If focus oscillates then reduce KP

Adjust KP,KD,RATE,DELAY to achieve fastest response without flicker or oscillation. This can be tested by either pushing down on the stage or manually adjusting the coarse focus whilst looking at the image. At best the LF210 will respond quick enough for the image not to go out of focus. Be aware that Prior NanoScanZ has limited travel (± 100 microns or ± 200 microns) so focus correction can only be within this range.

- CONFIG,s

For LF100K and H122 stepper motor connected to fine focus of microscope (100 microns per revolution.

Remember to type SAVE so that LF210 will power up in the configuration.

The default settings are shown and suggested settings for each objective. Note the following:-

Parameters shown in bold should be the first to be adjusted if further improvement is required.

High values of KP will show oscillation, small values will show slow response. As a rule of thumb use ratios for KP which are the inverse of square of the ratio of magnifications i.e. $KP(x50)=4*kp(x100)$

FOCUS value determines how far from best focus before servo action is initiated. It is a deadband either side of best focus. Too small a value will show constant corrections which will be seen as a flicker of the image. Too large a value will result in the image being able to go too far out of best focus before corrective action.

Parameters shown in italics should be left alone and will have no effect on servo behaviour.

Parameter	default	x5	x10	x20	x50	x100
kp	50	4000	4000	1000	500	200
kd	0					
ki	0					
<i>rate</i>	<i>1</i>					
<i>delay</i>	<i>0</i>					
<i>delayd</i>	<i>0</i>					
<i>lag</i>	<i>1</i>					
<i>laser</i>	<i>2000</i>					
inhibit	500					
focus	8000	1000	2000	3000	8000	8000
<i>offset</i>	<i>0,0</i>					
mode	2					
<i>reflect</i>	<i>0</i>					

- **Config,n**

For pin 3 of 15 way output socket (Piezo Output) connected to 0-10V voltage input of Prior NanoScanZ

Parameters shown in bold should be the first to be adjusted if further improvement is required.

High values of KP will show oscillation, small values will show slow response. As a rule of thumb use ratios for KP which are the inverse of square of the ratio of magnifications i.e. $KP(x50)=4*kp(x100)$

Rate determines how quickly the Output voltage can change. Since the depth of field of low power objectives is high the Rate needs to be higher for the servo action to correct for large focus shifts.

Delay is set to zero for high power objectives otherwise the user can observe the delay due to the small depth of field.

FOCUS value determines how far from best focus before servo action is initiated. It is a deadband either side of best focus. Too small a value will show constant corrections which will be seen as a flicker of the image. Too large a value will result in the image being able to go too far out of best focus before corrective action.

Parameters shown in italics should be left alone and will have no effect on servo behaviour.

Looking at the graphs below showing the sensitivity of the LF210 for different objectives it is clear that it is most sensitive for high magnifications., therefore kp can be reduced.

Parameter	default	x5	x10	x20	x50	x100
kp	100	2000	1000	1000	100	25
kd	500					
ki	0					
rate	5	200	100	50	5	5
delay	0	200	200	200	0	0
delayd	0					
lag	1					

laser	2000					
inhibit	500					
focus	8000	1000	2000	3000	8000	8000
offset	0,0					
mode	2					
reflect	0					

Depth of field

Prior NanoScanZ is a very sensitive Z stage and can be used as an accurate Z positioner when used with LF210 in MODE,2 (open loop)

OUTPUT,0,10000 will set Piezo voltage range of LF210 0V-10V which is 0-100 micron travel of NanoScanZ

PIEZO command can be used to move the NanoScanZ with an absolute position range 0-4095, thus having a theoretical resolution of 0.025microns.

PIEZO command can be used to step the sample position until the observer sees the image just going out of focus.

The DOF is the +/- range within which the image is not observed to be going out of focus.

FOCUS value is typically half the value at which INFOCUS flag stops toggling. Thus the FOCUS value will ensure that the image stays well within the DOF in MODE,1

	x5	x10	x20	x50	x100
NA	0.1	0.25	0.4	0.75	0.9
DOF(+/- microns)	12.0	2.5	1.25	0.4	0.1
FOCUS	1000	2000	3000	8000	8000

Graphs below show representative behaviour using a reflective wafer as a surface.

Prior NanoScanZ is used to move the sample +/-2047 counts either side of best focus (+/-50 microns)

Green trace is (A+B)

Red trace is Calculated Spot Position.

The cursors show the approximate Z range of linear behaviour of the Calculated Spot Position .

Note that correct servo action is possible provided Calculated Spot Position does not cross zero.(This would result in positive feedback)

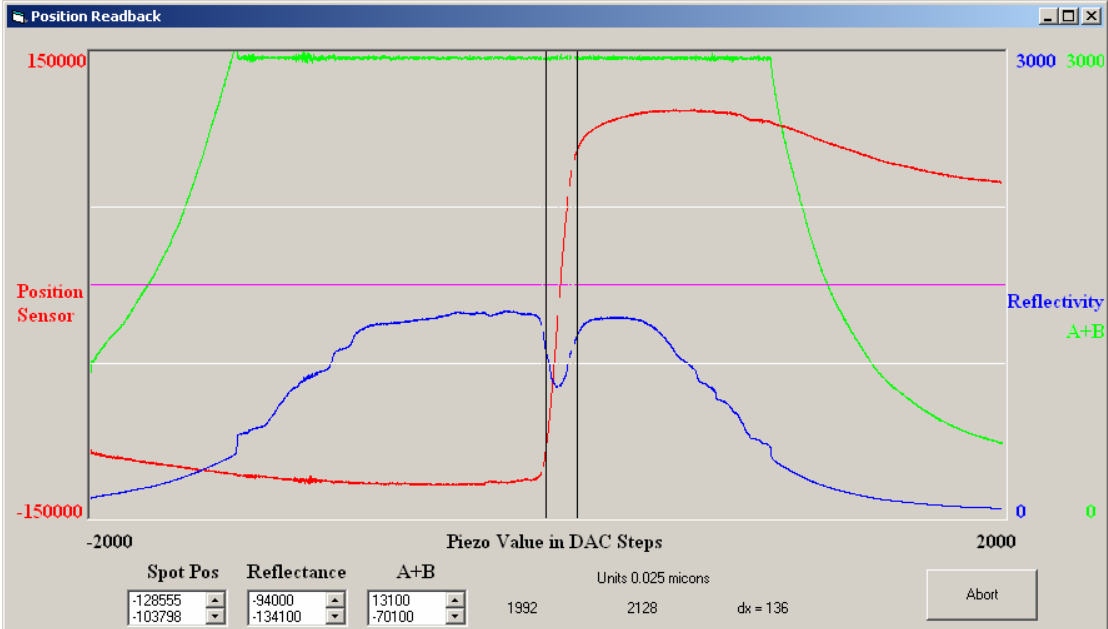

X100 Linear range is +/- 1.7 microns

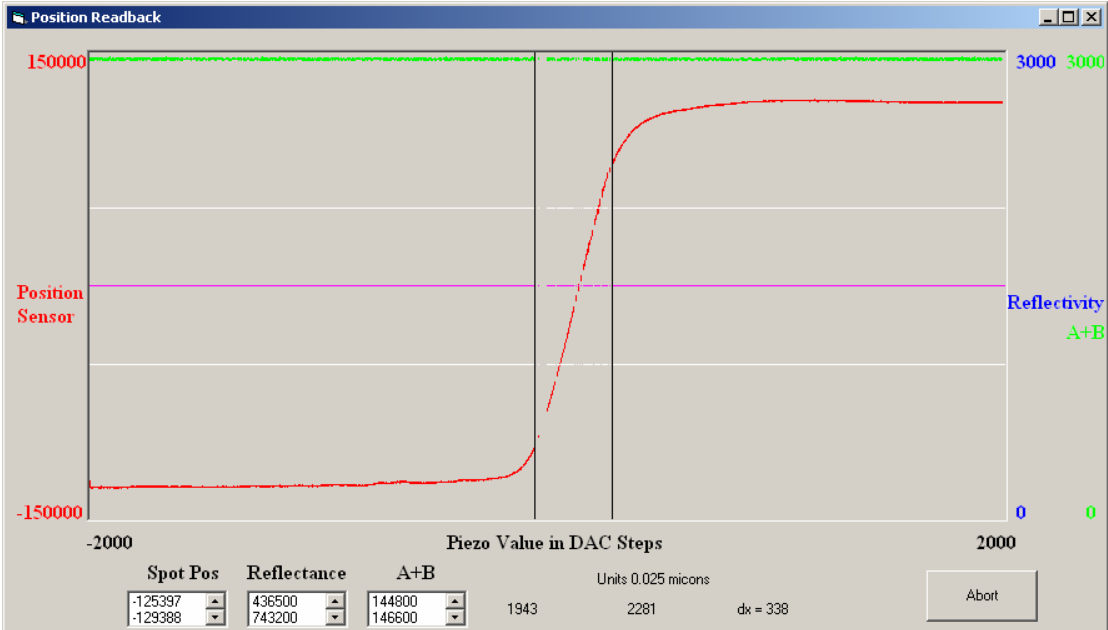

X50 Linear range is +/-4.2 microns

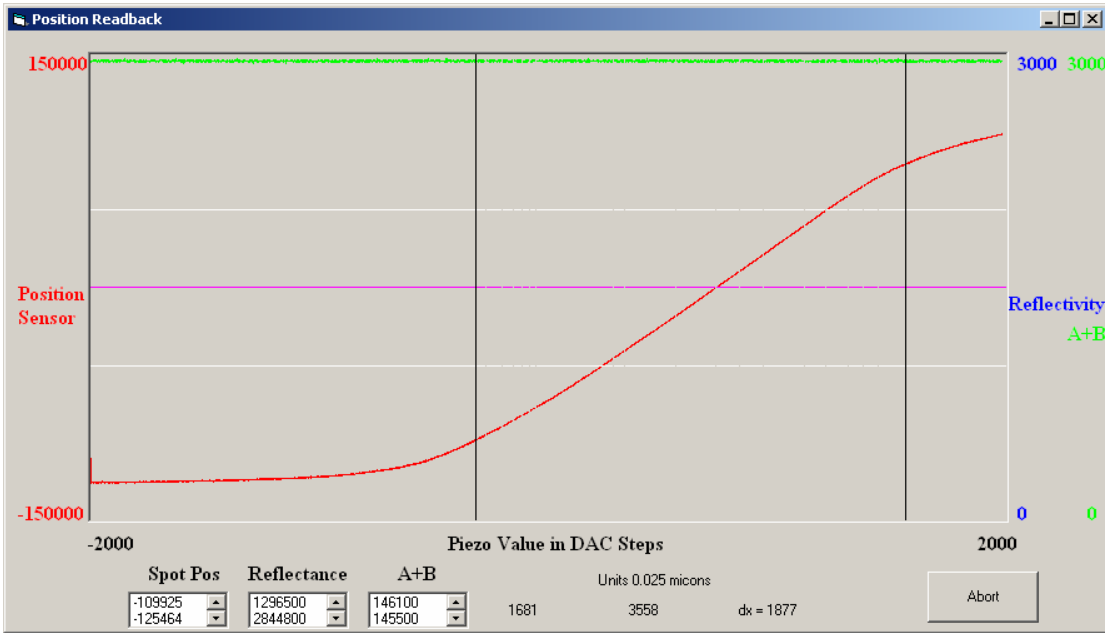

X20 Linear range is +/-23.0 microns

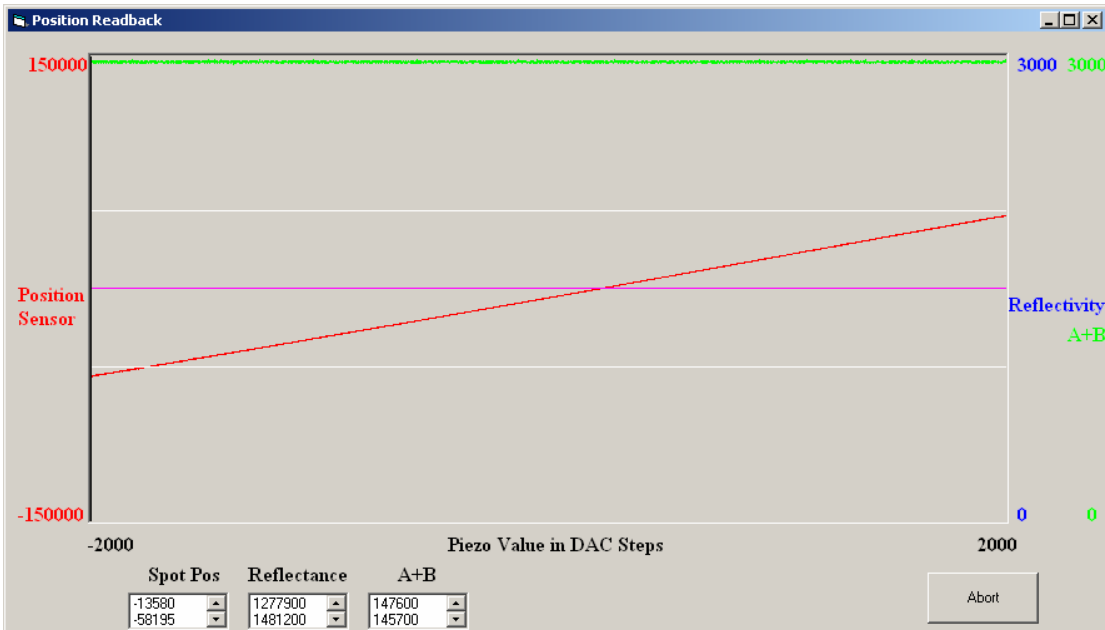

X10 Linear range >+/-50 microns

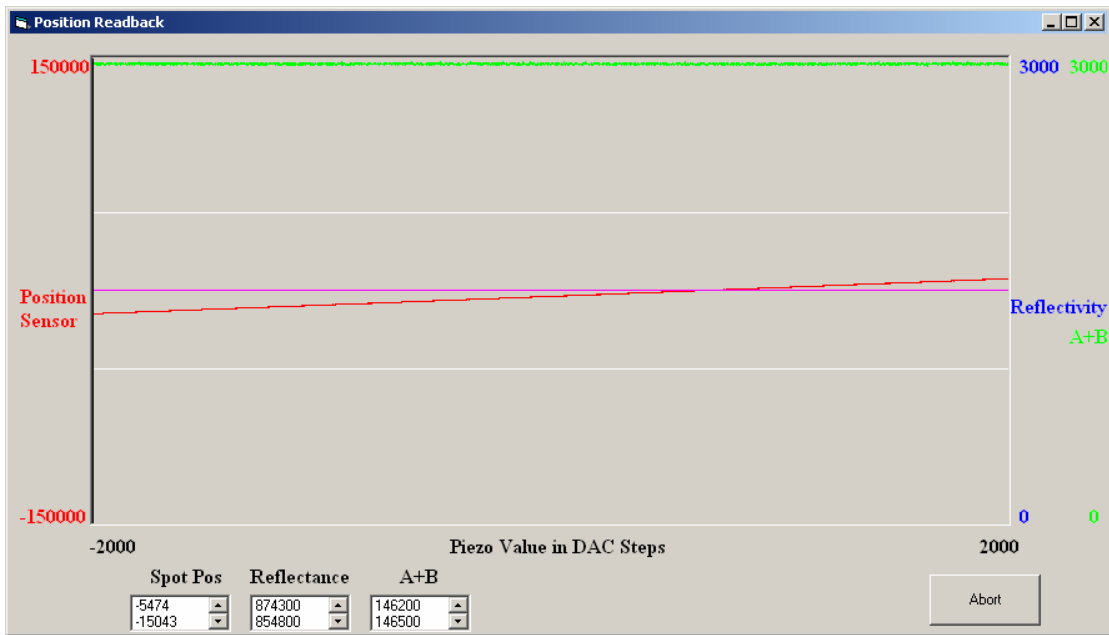

X5 Linear range >+/- 50 microns.

Graphs below show the dynamic behaviour of the unit.

All settings (see LIST ?) are as shown above.

The sample is moved +50 microns and set to MODE,1 (servo) and the servo dynamics captured.

MODE,2

The sample is then moved -50 microns and then set to MODE,1

Blue trace is the PIEZO voltage

Red Trace is Calculated Spot Position

Dual yellow lines show FOCUS value either side of TARGET within which unit is considered to be in focus.

Magenta trace is the INFOCUS flag.

It can be seen that x5,x10 and x20 objectives come into focus <200msecs

x50,x100 pull into focus <500msecs.

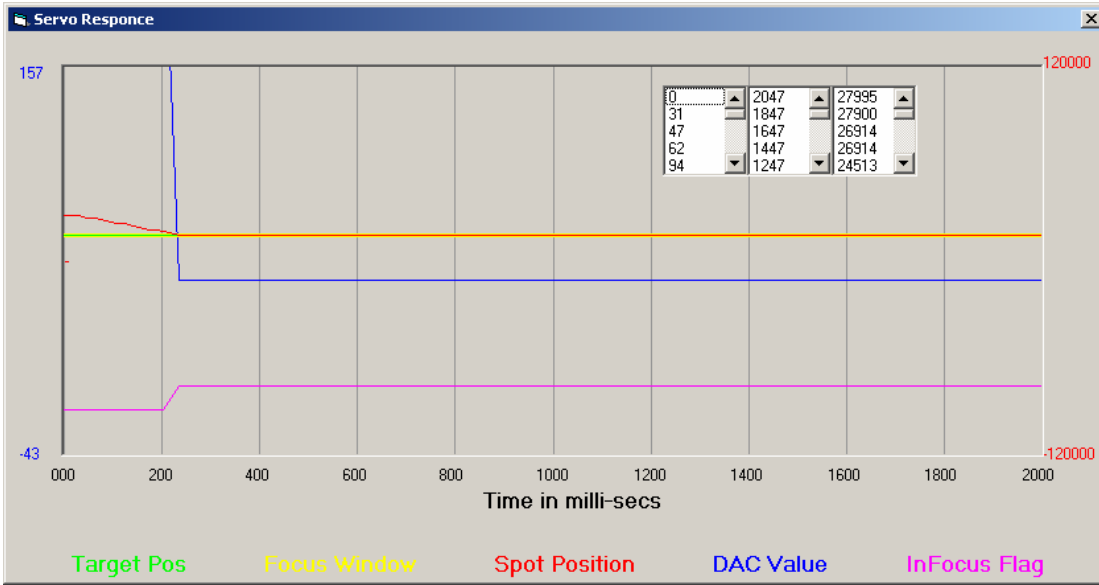

X5 PIEZO, 2000

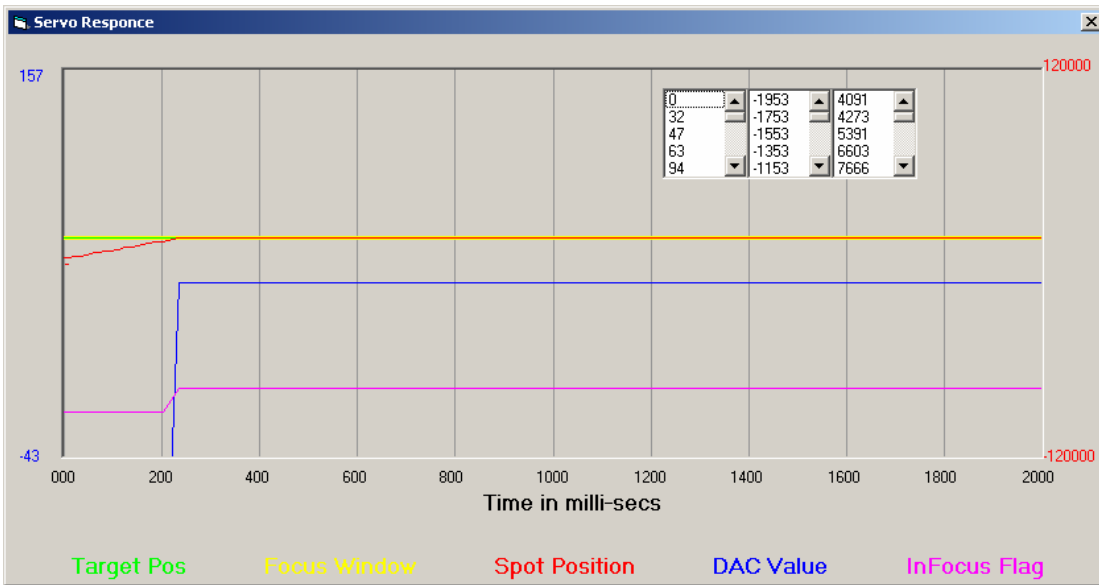

X5 PIEZO, -2000

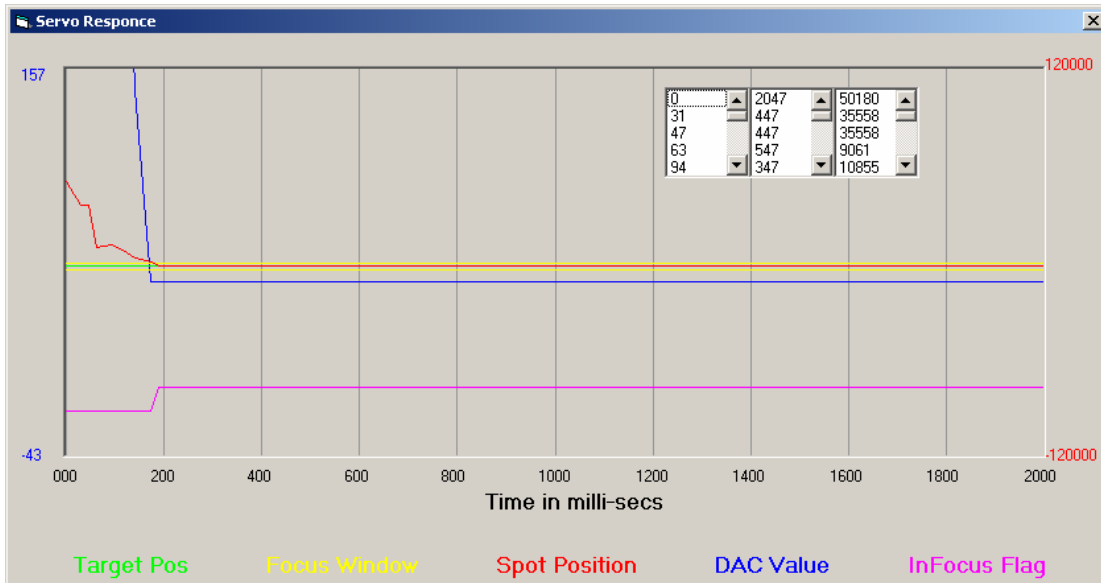

X10 PIEZO,2000

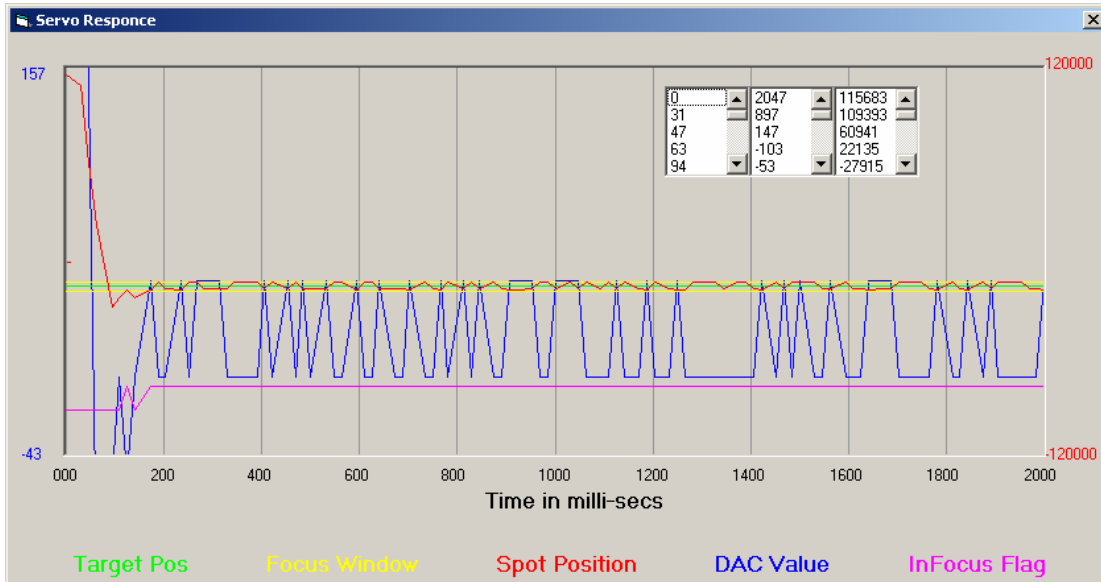

X20 PIEZO,2000

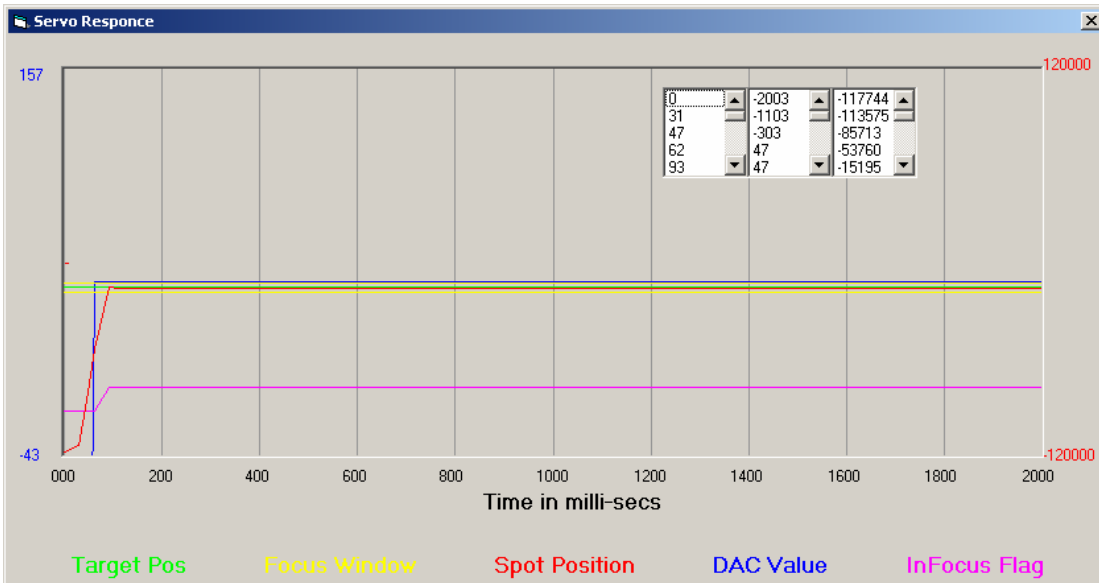

X20 PIEZO,-2000

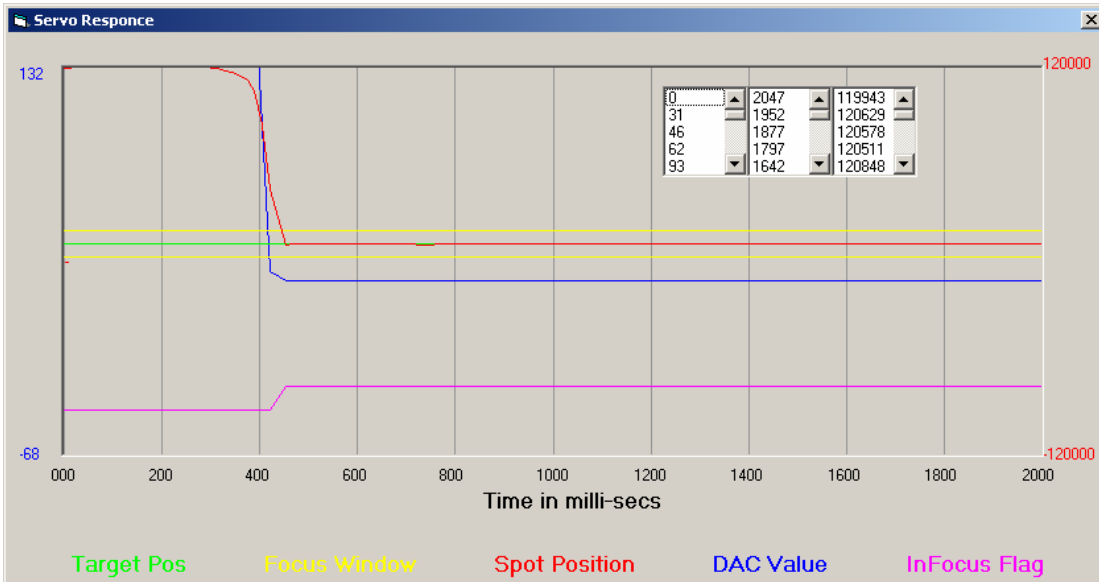

X50 PIEZO,2000

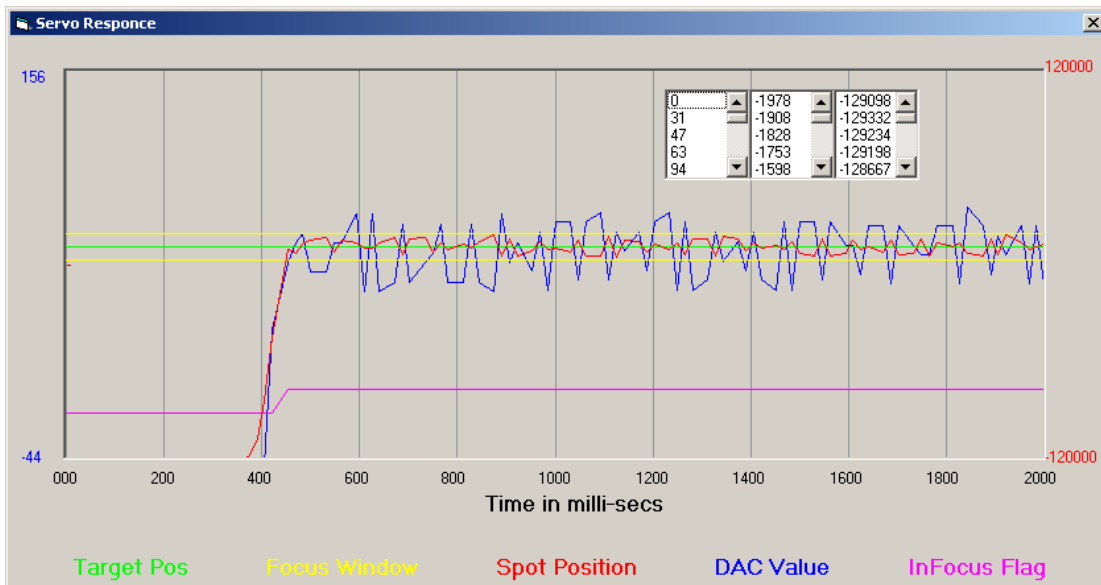

X50 PIEZO,-2000

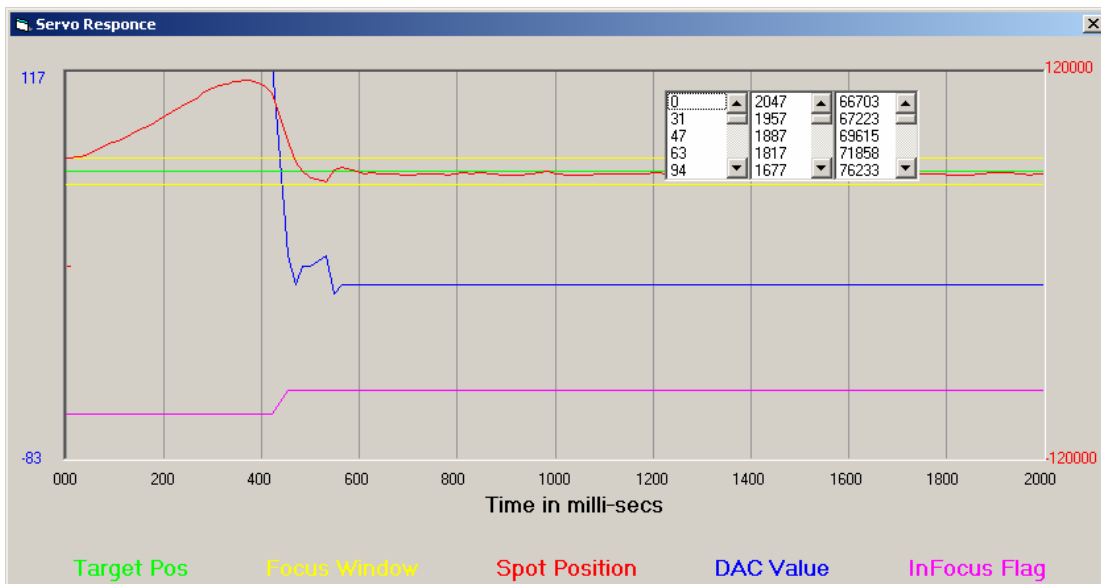

X100 PIEZO,2000

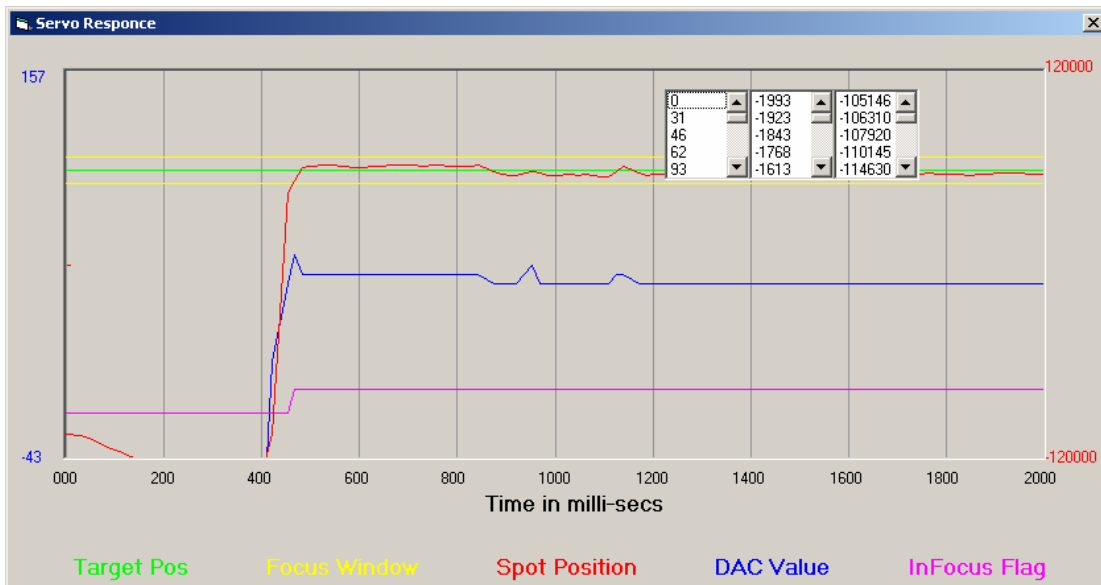

X100 PIEZO,-2000

10. Troubleshooting

Troubleshooting

Problem:

LF210 is totally inactive when switched on using the rocker switch. The green led of the power supply is not lit

Suggestions:

Check that the mains socket used by the PSU is live (plug in another electrical appliance). Check the fuse in the mains plug (if present), or alternatively replace mains cable with another which is known to work with another appliance. Pull out the 2.5mm socket from (LF210) to see if unit is shorting out the output of the PSU. If the led on the PSU remains off then it is likely that PSU is faulty and needs replacement.

WARNING

Replace +5V 35W PSU with genuine Prior replacement (Prior part number W?) otherwise permanent damage can be done to LF210

Problem:

The unit is totally inactive when switched on using the rocker switch. The green led of PSU is on.

Suggestions:

The DIGIPOT led should be on when power is applied to the unit. If no led is lit then the unit has no power. Although the green led of PSU is on it may be that the PSU is still faulty. Switch PSU off by removing the mains. Reapply mains power to PSU. If fault persists then return complete system back to Prior.

11. System Specifications

System Specifications

(All Dimensions in mm)

PART No.	DESCRIPTION	DIMENSIONS (L x W x D)	WEIGHT
LF210	LaserFocus unit		
LF100K	Keypad for stand-alone operation of LF210		

Power

Universal integral power supply (for LF210 LaserFocus unit)

Input: 90 - 265V 110 - 240V, 50/60Hz 15VA

Output: 5VDC 20VA

Universal integral power supply (for LF100K Keypad with integral stepper motor drive)

Input: 90 - 265V 110 - 240V, 50/60Hz 15VA

Output: 24VDC 60VA

Specifications subject to change without notice.

12. *Glossary of Terms*

Glossary of Terms

Aperture - The area which is available for the passage of light

Autofocus - The ability of a Z focus system to automatically find the correct focus

Coarse Focus Knob - The large knob on the side of a microscope that moves the stage up and down relatively large distances with relatively small motion.

Controller - The device which provides positional control to the stage, focus drive, filter wheel, or shutter.

Digipot - A circular device/encoder, typically mounted on a joystick used to manually rotate the fine focus knob. The digipot rotates the focus knob at an angle relative to the angular movement of the rotation of the digipot.

Encoder - A feedback device which provides positional information for either an XY stage or the focus drive assembly. Encoders can either be rotary or linear.

Fine Focus Knob - The small knob on the side of the microscope that moves the stage up and down relatively small amounts with relatively large movements. Typically 100 microns per revolution of the fine focus knob.

Flash Memory Capability - The ability of the Prior controller to download new software without requiring an EPROM change. This ability is analogous to that of a solid state hard drive.

Focus Drive - A motor and adapter assembly that typically mounts to the coarse focus knob of a microscope and drives the fine focus knob.

Hyperterminal - A terminal emulation program provided with Windows 95,98 NT. Instructions for setting up Hyperterminal to communicate with the Prior controller are located in the appendices.

Incident Illumination - Light which falls on the object from the same direction as viewing.

Inverted Microscope - A microscope that views the object from below. The objectives are underneath the stage.

Open Loop System - A control system that has no means of comparing the output with the input for control purposes. Open loop stage systems rely on the controller to send the proper amount of pulses to the motor to achieve the required movement.

RS-232 - A communication standard which specifies electrical, mechanical and functional characteristics for serial binary communication circuits in a point to point link. Commands from a computer's COM port travel to the controller via RS-232.

Serial Control - A type of information transfer where the bits are handled sequentially

Stepper Motor - A motor which when current is applied generates a holding torque. The motor is rotated by switching the coils on and off. The step motors in Prior stages and focus motors generally have 200 steps per revolution, which is then microstepped to 50,000 microsteps per revolution.

TTL - Transistor-Transistor Logic. An integrated circuit with its inputs and outputs directly tied to transistors. Inputs and outputs are low voltage (<1 VDC) and high voltage (>3 VDC).

Transmitted Illumination - Light which passes through the object

Upright Microscope - A microscope that views the object from above

XYZ - The term used to describe the axes of a microscope that move left/right(X), front/back(Y) and up/down(Z)

13. Replacement Parts

Replacement Parts

Description Part Number

Accessories

Focus Drive and Adapter	H122
Focus Drive and Adapter for Zeiss	H122AXIO
RS232 cable for PC (9 or 25 pin)	H276K
RS232 cable for Macintosh	H277
Solid Couple Adapter for Focus Drive on Olympus/Nikon	H122KON
Solid Couple Adapter for Focus Drive on Leica	H122KLC

14. Returns and Repairs

Returns and Repairs

Should you experience problems with your ProScan System and want to send it back for service, warranty or otherwise, a Return Material Authorisation (RMA) number must be obtained from the appropriate Prior Scientific office before returning any equipment. For North and South America contact Prior Scientific Inc. and for the rest of the world call Prior Scientific Instruments Limited on the telephone numbers shown below.

<p>Prior Scientific Instruments Limited</p> <p>Units3/4</p> <p>Fielding Industrial Estate</p> <p>Wilbraham Road,</p> <p>Fulbourn,</p> <p>Cambridge,</p> <p>England,</p> <p>CB1 5ET</p> <p>Telephone +44(0)1223 881711</p> <p>FAX +44(0)1223 881710</p> <p>email:uksales@prior.com</p>	<p>Prior Scientific Inc.</p> <p>80 Reservoir Park Drive,</p> <p>Rockland,</p> <p>MA 02370-1062</p> <p>USA</p> <p>Telephone 781 878 8442</p> <p>FAX 781 878 8736</p> <p>email: info@prior.com</p>
---	--

15. *Appendices*

Appendix A

How to Run HyperTerminal

Instructions for using Windows HyperTerminal Emulation Program for communication to Prior Controller.

- 1) Click Start, then Programs, then Accessories, then HyperTerminal.
- 2) Select the “HyperTerminal” icon.
- 3) In the “Connection description” dialog box enter filename e.g. priorLF210, select an icon and press OK.
- 4) In the “Connect to” dialog box enter Phone Number (if required) and Select the correct COM port and press OK.
- 5) Enter the following parameters in the Port Settings box ;

Bits per second	115200
Data bits	8
Parity	None
Stop bits	1
Flow control	None

- 6) Press OK button.
- 7) Select File, Properties and Settings tab.
- 8) Press ASCII Setup...
- 9) Select “Echo typed characters locally” and “Append line feeds to incoming line ends” (you should find that “Wrap lines that exceed terminal width” has already been selected).
- 10) Press OK
- 11) Press OK.

**MAXIMUM OUTPUT @ 690nm <1mW
CLASSIFIED TO BS EN 60825-1:1994**



CLASS 1 LASER PRODUCT

LF210 is a Class 1 Laser Product emitting laser light at a power less than 1mW as a collimated beam 6mm diameter. The wavelength is 680-695nm.

As such the product is safe to use without eye protection. However it is normal safe practice to avoid removal of LF210 from the microscope without first disconnecting it from its PSU

Never point the laser beam directly into the eye (look into the source of the laser beam)

**CAUTION - CLASS 3B LASER RADIATION
WHEN OPEN AND INTERLOCKS DEFEATED
DO NOT STARE INTO BEAM**

LF 210 contains a high power laser diode. The laser diode emits up to 35mW continuous power (CW) at 680-695nm . The laser emits visible light. As such this is a Class3B laser product. The LF210 is assembled using tamper proof screws and an interlock which removes power from the laser when the lid is removed from the base.

UNDER NO CIRCUMSTANCES should an unqualified person attempt to remove the lid from the base of this product. This could render the product as a laser hazard. This can only be done by a qualified Prior Scientific Engineer who has training in assembly and repair of laser products.

Appendix B

Loading Firmware

1. Loading firmware into Renesas H8/3048BF processor.
2. This is normally of no concern to user unless it is required to load new version of firmware for bug fixes and/or performance enhancements.
3. Run Renesas Flash Development Toolkit 3.1
4. Project
 Insert Project.....
 Project name e.g. PriorLF210
 Leave all other windows as the default
5. Select Device H8/3048BF
6. Select Port Use dropdown to select the correct RS232 port
7. Enter CPU frequency
 22.1184MHz
8. Leave radio button as BOOT MODE
9. Leave programming options as defaults.
10. Press Finish
11. Select menu tab Tools Simple Interface.....
12. Select option Download file
13. Use the browse button (at right of window) to select the .a20 file to download.
 The operator will have copied the correct .a20 file to a folder of choice
14. We have now configured this software to download the new .20 file.
 We need to put LF210 into correct mode to accept this file. It is safest to exit this software at this point.
15. Press EXIT. Important do not press 'Back to Project' as this will loose the Simple Interface settings we have just created the next time this software is run.
16. Run HyperTerminal to communicate with LF210

17. Type PROG

The LF210 will return with a message Entering Programming Mode

18. Exit HyperTerminal

19. Run Flash Development Toolkit 3.1 software again. It will start with the Simple Interface window as configured above.

20. Press Program Flash

21. Wait until the download has completed successfully

22. Press Disconnect

23. Press exit

24. Power cycle LF210

25. Connect HyperTerminal again

26. Type VER<cr> to confirm the correct version of firmware has been loaded.

Part No: W3571, Version 1, 21/10/08